

Uninterruptible power supply - STEP-UPS/12DC/12DC/4 - 2868693

Please be informed that the data shown in this PDF Document is generated from our Online Catalog. Please find the complete data in the user's documentation. Our General Terms of Use for Downloads are valid (<http://phoenixcontact.com/download>)



Uninterruptible power supply with integrated battery module. The STEP-BAT/LIPO/18.5 DC/1.4 AH battery module can be re-ordered separately.

Product Description

UPS modules with integrated energy storage are particularly space saving: UPS module and energy storage are combined in one housing. It's just a case of connecting a power supply upstream.

Your advantages

- UPS with integrated LiPo-based energy storage

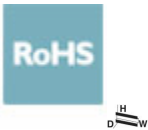

Key Commercial Data

Packing unit	1 pc
GTIN	 4 046356 519922
GTIN	4046356519922
Weight per Piece (excluding packing)	600.000 g
Custom tariff number	85371091
Country of origin	Germany

Technical data

Dimensions

Width	108 mm
Height	90 mm
Depth	61 mm
Installation distance right/left	0 mm / 0 mm
Installation distance top/bottom	0 mm / 0 mm

Ambient conditions

Uninterruptible power supply - STEP-UPS/12DC/12DC/4 - 2868693

Technical data

Ambient conditions

Degree of protection	IP20
Ambient temperature (operation)	0 °C ... 40 °C
Ambient temperature (storage/transport)	-20 °C ... 45 °C
Max. permissible relative humidity (operation)	≤ 95 % (at 25 °C, non-condensing)
Climatic class	3K3 (in acc. with EN 60721)
Degree of pollution	2

Input data

Input voltage	12 V DC
Nominal input voltage	12 V DC
Input voltage range	10 V DC ... 16.5 V DC
Current consumption (charging process)	< 0.8 A (Charging (I _{Charge} = max, I _{Out} = 0))
Current consumption (maximum)	6 A
Current consumption (idle)	< 30 mA
Fixed backup threshold	< 10 V
Variable connect threshold	1 V / 1 s
Input fuse, integrated	7 A (slow-blow, internal)

Output data (12 V DC mains operation)

Nominal output voltage	12 V DC
Nominal output current (I _N)	4 A (0 °C ... 40 °C)

Output data (12 V DC battery operation)

Nominal output voltage	12 V DC
Output voltage range (depends on the input voltage)	10 V DC ... 15 V DC (U _{Out} = U _{In (t-1)})
Nominal output current (I _N)	4 A (0 °C ... 40 °C)

General output data

Efficiency	> 97.4 % (Mains operation, with charged energy storage)
------------	---

General

IQ technology	no
Net weight	0.46 kg
Memory medium	Lithium polymer
Protection class	III
MTBF (IEC 61709, SN 29500)	> 1997000 h (40 °C)
Mounting position	horizontal DIN rail NS 35, EN 60715
Assembly instructions	alignable: horizontally 0 mm, vertically 50 mm

Connection data, input

Uninterruptible power supply - STEP-UPS/12DC/12DC/4 - 2868693

Technical data

Connection data, input

Connection method	Screw connection
Conductor cross section solid min.	0.2 mm ²
Conductor cross section solid max.	2.5 mm ²
Conductor cross section flexible min.	0.2 mm ²
Conductor cross section flexible max.	2.5 mm ²
Conductor cross section AWG min.	24
Conductor cross section AWG max.	12
Stripping length	6.5 mm
Screw thread	M3

Connection data, output

Connection method	Screw connection
Conductor cross section solid min.	0.2 mm ²
Conductor cross section solid max.	2.5 mm ²
Conductor cross section flexible min.	0.2 mm ²
Conductor cross section flexible max.	2.5 mm ²
Conductor cross section AWG min.	24
Conductor cross section AWG max.	12
Stripping length	6.5 mm
Screw thread	M3

Connection data for signaling

Conductor cross section solid min.	0.2 mm ²
Conductor cross section solid max.	2.5 mm ²
Conductor cross section flexible min.	0.2 mm ²
Conductor cross section flexible max.	2.5 mm ²
Conductor cross section AWG min.	24
Conductor cross section AWG max.	12
Stripping length	6.5 mm
Screw thread	M3

Charging process

Quality check of battery	Yes, every time it is charged and cyclically once a month
Deep discharge protection	< 15 V DC

Standards

EMC requirements for noise immunity	EN 61000-6-1
	EN 61000-6-2
EMC requirements for noise emission	EN 61000-6-3

Uninterruptible power supply - STEP-UPS/12DC/12DC/4 - 2868693

Technical data

Standards

	EN 61000-6-4
Standard - Electrical safety	EN 60950-1/VDE 0805 (SELV)
Standard – Electronic equipment for use in electrical power installations and their assembly into electrical power installations	EN 50178/VDE 0160 (PELV)

Conformance/approvals

UL approvals	UL Listed UL 508
	UL/C-UL Recognized UL 60950-1

EMC data

Electromagnetic compatibility	Conformance with EMC Directive 2014/30/EU
Electrostatic discharge	EN 61000-4-2
Contact discharge	6 kV (Test Level 3)
Discharge in air	8 kV (Test Level 3)
Electromagnetic HF field	EN 61000-4-3
Frequency range	80 MHz ... 1 GHz
Test field strength	10 V/m (Test Level 3)
Frequency range	1 GHz ... 2 GHz
Test field strength	10 V/m (Test Level 3)
Frequency range	2 GHz ... 3 GHz
Test field strength	10 V/m (Test Level 3)
Comments	Criterion A
Fast transients (burst)	EN 61000-4-4
Input	2 kV (Test Level 3 - asymmetrical)
Output	2 kV (Test Level 3 - asymmetrical)
Signal	2 kV (Test Level 4 - asymmetrical)
Comments	Criterion A
Surge voltage load (surge)	EN 61000-4-5
Input	1 kV (Test Level 2 - symmetrical)
	2 kV (Test Level 3 - asymmetrical)
Output	1 kV (Test Level 2 - symmetrical)
	2 kV (Test Level 3 - asymmetrical)
Signal	1 kV (Test Level 2 - asymmetrical)
Comments	Criterion A
Conducted interference	EN 61000-4-6
I/O/S	asymmetrical
Frequency range	0.15 MHz ... 80 MHz
Voltage	10 V (Test Level 3)
Comments	Criterion A

Uninterruptible power supply - STEP-UPS/12DC/12DC/4 - 2868693

Technical data

EMC data

Criterion A	Normal operating behavior within the specified limits.
Criterion B	Temporary impairment to operational behavior that is corrected by the device itself.

Environmental Product Compliance

REACH SVHC	Lead 7439-92-1
China RoHS	Environmentally Friendly Use Period = 25;
	For details about hazardous substances go to tab "Downloads", Category "Manufacturer's declaration"

Drawings

Block diagram

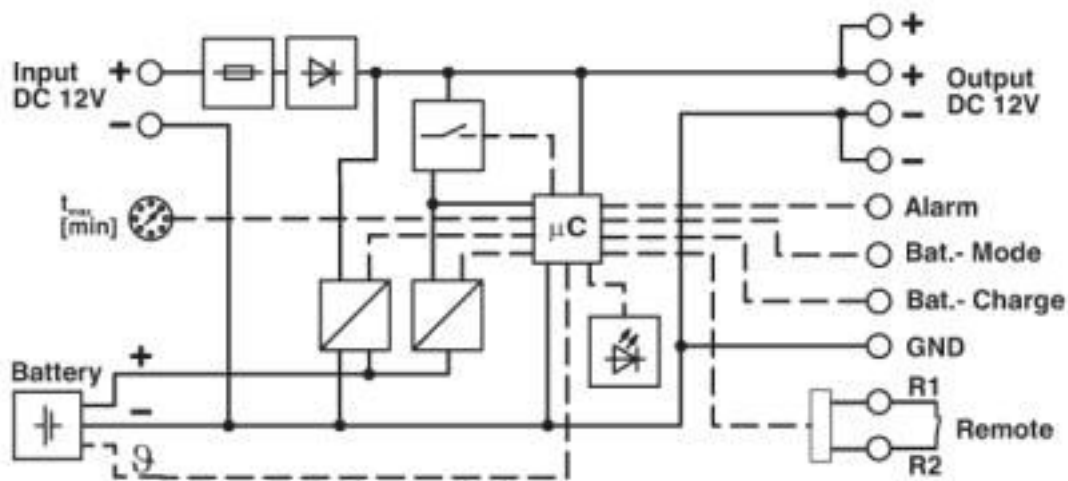

Classifications

eCl@ss

eCl@ss 10.0.1	27040705
eCl@ss 4.0	27040600
eCl@ss 4.1	27040600
eCl@ss 5.0	27040600
eCl@ss 5.1	27040600
eCl@ss 6.0	27040600
eCl@ss 7.0	27040603
eCl@ss 8.0	27040603
eCl@ss 9.0	27040705

Uninterruptible power supply - STEP-UPS/12DC/12DC/4 - 2868693

Classifications

ETIM

ETIM 4.0	EC000382
ETIM 5.0	EC000382
ETIM 6.0	EC000382
ETIM 7.0	EC000382

UNSPSC

UNSPSC 6.01	30211510
UNSPSC 7.0901	39121011
UNSPSC 11	39121011
UNSPSC 12.01	39121011
UNSPSC 13.2	39121011
UNSPSC 18.0	39121011
UNSPSC 19.0	39121011
UNSPSC 20.0	39121011
UNSPSC 21.0	39121011

Approvals

Approvals

Approvals

UL Listed / UL Recognized / cUL Recognized / IEC CB Scheme / cUL Listed / EAC / EAC / cULus Recognized / cULus Listed

Ex Approvals

Approval details

UL Listed		http://database.ul.com/cgi-bin/XYV/template/LISEXT/1FRAME/index.htm	FILE E 123528
-----------	--	---	---------------

UL Recognized		http://database.ul.com/cgi-bin/XYV/template/LISEXT/1FRAME/index.htm	FILE E 214596
---------------	--	---	---------------

Uninterruptible power supply - STEP-UPS/12DC/12DC/4 - 2868693

Approvals

cUL Recognized		http://database.ul.com/cgi-bin/XYV/template/LISEXT/1FRAME/index.htm	FILE E 214596
----------------	--	---	---------------

IECEE CB Scheme		http://www.iecee.org/	DK-28030
-----------------	--	---	----------

cUL Listed		http://database.ul.com/cgi-bin/XYV/template/LISEXT/1FRAME/index.htm	FILE E 123528
------------	--	---	---------------

EAC			EAC-Zulassung
-----	--	--	---------------

EAC			RU*DE*08.B.01873/19
-----	--	--	---------------------

cULus Recognized			
------------------	--	--	--

cULus Listed			
--------------	--	--	--

Accessories

Accessories

Battery unit

Battery - STEP-BAT/LIPO/18.5DC/1.4AH - 2320364



Replacement battery module, lithium polymer, 18.5 V DC, 1.4 Ah.

Uninterruptible power supply - STEP-UPS/12DC/12DC/4 - 2868693

Accessories

Power supply

Power supply unit - STEP-PS/ 1AC/12DC/5 - 2868583



Primary-switched STEP POWER power supply for DIN rail mounting, input: 1-phase, output: 12 V DC/5 A