

Monitoring relay - EMD-SL-3V-400 - 2866051

Please be informed that the data shown in this PDF Document is generated from our Online Catalog. Please find the complete data in the user's documentation. Our General Terms of Use for Downloads are valid (<http://phoenixcontact.com/download>)



Monitoring relay for monitoring 3-phase voltages of 280...520 V AC, window, without neutral conductor connection, supply voltage can be selected using power module, 1 PDT

Product Description

Increasingly higher demands are being placed on safety and system availability - across all sectors. Processes are becoming more and more complex, not only in mechanical engineering and the chemical industry, but also in plant and automation technology. Demands on power engineering are also increasing constantly.

Error-free and therefore cost-effective operation can only be achieved through continuous monitoring of important network and system parameters. Electronic monitoring relays in the EMD series are available for a wide range of monitoring tasks to avoid the consequences of errors or to keep them within limits.

The operating states are indicated using colored LEDs, errors that may occur can be sent to a control system via a floating contact or can shut down a part of the system. Some device versions are equipped with startup and response delays in order to briefly tolerate measured values outside the set monitoring range.

Your advantages

- Adjustable response delay
- Variable supply voltage range
- Adjustable via potentiometer on the front
- Adjustable asymmetry



Key Commercial Data

Packing unit	1 pc
GTIN	 4 017918 952655
GTIN	4017918952655
Weight per Piece (excluding packing)	137.000 g
Custom tariff number	85364900
Country of origin	Austria

Monitoring relay - EMD-SL-3V-400 - 2866051

Technical data

Dimensions

Width	22.5 mm
Height	90 mm
Depth	113 mm

Ambient conditions

Ambient temperature (operation)	-25 °C ... 55 °C
	-25 °C ... 40 °C (corresponds to UL 508)
Ambient temperature (storage/transport)	-25 °C ... 70 °C
Permissible humidity (operation)	15 % ... 85 %
Degree of protection	IP40 (Housing)
	IP20 (Connection terminal blocks)
Noise immunity	EN 61000-6-2

Input data

Nominal input voltage U_N	3 ~ 400 V
Maximum temperature coefficient	< 0.1 %/K
Function	Window, without neutral conductor connection
Min. setting range	-30 % ... 20 % (From U_N)
Max. setting range	-20 % ... 30 % (From U_N)
Min setting range of the voltage threshold value	280 V AC ... 480 V AC
Max. setting range of the voltage threshold value	320 V AC ... 520 V AC
Setting range for response delay	0.2 s ... 10 s
Basic accuracy	± 5 % (of scale end value)
Setting accuracy	≤ 5 % (of scale end value)
Repeat accuracy	≤ 2 %
Voltage influence	≤ 0.5 %
Recovery time	500 ms

Contact side

Contact type	1 floating PDT
Maximum switching voltage	250 V AC (in acc. with IEC 60664-1)
Interrupting rating (ohmic load) max.	750 VA (3 A/250 V AC, module aligned, ≤ 5 mm spacing)
	1250 VA (5 A/250 V AC, module not aligned, ≥ 5 mm spacing)
Output fuse	5 A (fast-blow)

Power supply

Supply voltage range	24 V AC ... 230 V AC (see Power modules)
	24 V DC (see Power modules)

Monitoring relay - EMD-SL-3V-400 - 2866051

Technical data

General

Mechanical service life	approx. 2×10^7 cycles
Operating mode	100% operating factor
Mounting position	any
Assembly instructions	on standard DIN rail NS 35 in accordance with EN 60715
Electromagnetic compatibility	Conformance with EMC Directive 2004/108/EC
Housing insulation material	Polyamide PA, self-extinguishing
Color	green

Connection data

Connection method	Screw connection
Stripping length	8 mm
Conductor cross section solid	0.5 mm ² ... 2.5 mm ²
Conductor cross section flexible	0.25 mm ² ... 2.5 mm ²
Conductor cross section AWG	20 ... 14
Tightening torque	1 Nm

Standards and Regulations

Electromagnetic compatibility	Conformance with EMC Directive 2004/108/EC
Noise emission	EN 61000-6-3
Noise immunity	EN 61000-6-2
Standards/regulations	EN 50178
Rated insulation voltage	300 V
Insulation	Basic insulation
Pollution degree	2
Overvoltage category	III
Low Voltage Directive	Conformance with LV directive 2006/95/EC

Environmental Product Compliance

China RoHS	Environmentally friendly use period: unlimited = EFUP-e
	No hazardous substances above threshold values

Drawings

Monitoring relay - EMD-SL-3V-400 - 2866051

Block diagram

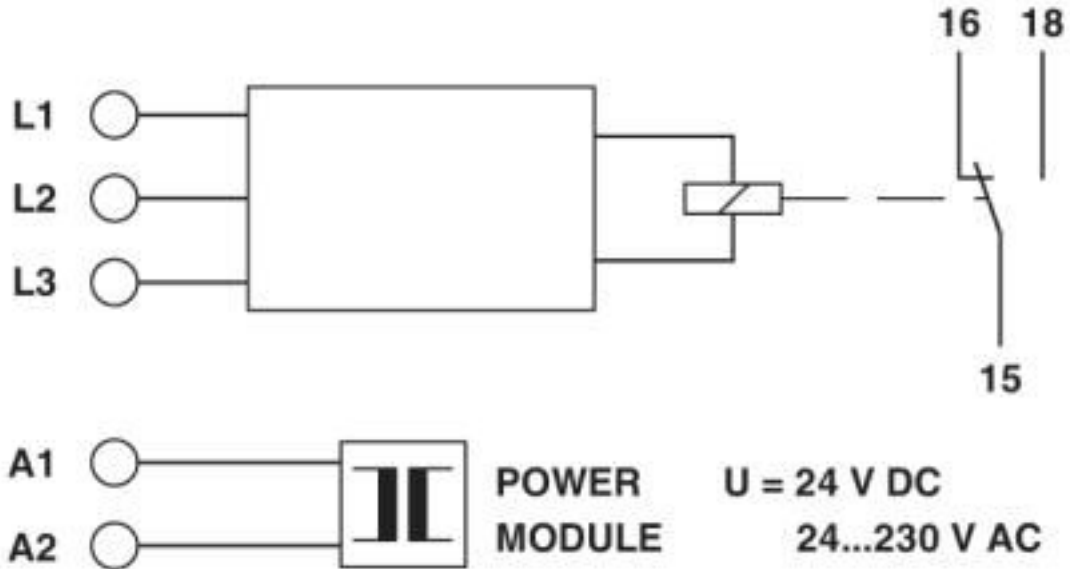

Classifications

eCl@ss

eCl@ss 10.0.1	27371801
eCl@ss 4.0	27371100
eCl@ss 4.1	27371100
eCl@ss 5.0	27371800
eCl@ss 5.1	27371800
eCl@ss 6.0	27371800
eCl@ss 7.0	27371801
eCl@ss 8.0	27371801
eCl@ss 9.0	27371801

ETIM

ETIM 2.0	EC001438
ETIM 3.0	EC001438
ETIM 4.0	EC001438
ETIM 5.0	EC001438
ETIM 6.0	EC001438
ETIM 7.0	EC001438

UNSPSC

UNSPSC 6.01	30211916
-------------	----------

Monitoring relay - EMD-SL-3V-400 - 2866051

Classifications

UNSPSC

UNSPSC 7.0901	39121535
UNSPSC 11	39121535
UNSPSC 12.01	39121535
UNSPSC 13.2	41113620
UNSPSC 18.0	41113620
UNSPSC 19.0	41113620
UNSPSC 20.0	41113620
UNSPSC 21.0	41113620

Approvals

Approvals

Approvals

UL Listed / cUL Listed / EAC / EAC / cULus Listed

Ex Approvals

Approval details

UL Listed		http://database.ul.com/cgi-bin/XYV/template/LISEXT/1FRAME/index.htm	FILE E 172140
-----------	--	---	---------------

cUL Listed		http://database.ul.com/cgi-bin/XYV/template/LISEXT/1FRAME/index.htm	FILE E 172140
------------	--	---	---------------

EAC			TR_TS_D_00573_c
-----	--	--	-----------------

EAC			RU*C- DE.*08.B.00010
-----	--	--	-------------------------

Monitoring relay - EMD-SL-3V-400 - 2866051

Approvals

cULus Listed



Accessories

Additional products

Power module - EMD-SL-PS- 24DC - 2885359



Power modules, pluggable, for EMD-SL-..., supply voltage: 20 V DC ... 30 V DC

Power module - EMD-SL-PS- 24AC - 2866103



Power modules, pluggable, for EMD-SL-..., supply voltage: 20.2...26.4 V AC

Power module - EMD-SL-PS-110AC - 2866116



Power modules, pluggable, for EMD-SL-..., supply voltage: 88...121 V AC

Power module - EMD-SL-PS-120AC - 2885731



Power modules, pluggable, for EMD-SL-..., supply voltage: 108 V AC ... 132 V AC

Monitoring relay - EMD-SL-3V-400 - 2866051

Accessories

Power module - EMD-SL-PS-230AC - 2866129



Power modules, pluggable, for EMD-SL-..., supply voltage: 195...264 V AC