

Type 2 surge protection plug - VAL-CP-350-ST - 2859602

Please be informed that the data shown in this PDF Document is generated from our Online Catalog. Please find the complete data in the user's documentation. Our General Terms of Use for Downloads are valid (<http://phoenixcontact.com/download>)



Replacement plug for VAL-CP surge protective device with high-capacity varistor with a low leakage current.



Key Commercial Data

Packing unit	1 pc
GTIN	 4 017918 956509
GTIN	4017918956509
Weight per Piece (excluding packing)	51.540 g
Custom tariff number	85363030
Country of origin	Germany

Technical data

Dimensions

Height	46.4 mm
Width	11.7 mm
Depth	56.4 mm
Horizontal pitch	0.6 Div.

Ambient conditions

Degree of protection	IP20
Ambient temperature (operation)	-40 °C ... 80 °C
Ambient temperature (storage/transport)	-40 °C ... 80 °C
Altitude	≤ 2000 m (amsl (above mean sea level))
Permissible humidity (operation)	5 % ... 95 %
Shock (operation)	30g (Half-sine / 11 ms / 3x ±X, ±Y, ±Z)

Type 2 surge protection plug - VAL-CP-350-ST - 2859602

Technical data

Ambient conditions

Vibration (operation)	5g (10 ... 500 Hz / 2.5 h / X, Y, Z)
-----------------------	--------------------------------------

General

IEC test classification	II
	T2
EN type	T2
IEC power supply system	TN
	TT
Mode of protection	L-N
	L-PEN
Mounting type	on base element
Color	gray/blue
Housing material	PBT-FR
Degree of pollution	2
Flammability rating according to UL 94	V-0
Type	DIN rail module, two-section, divisible
Number of positions	1
Surge protection fault message	optical

Protective circuit

Nominal voltage U_N	240 V AC (TN)
	240 V AC (TT)
Nominal frequency f_N	50 Hz (60 Hz)
Maximum continuous voltage U_C	350 V AC
Nominal discharge current I_n (8/20) μ s	20 kA
Maximum discharge current I_{max} (8/20) μ s	40 kA
Short-circuit current rating I_{SCCR}	25 kA
Voltage protection level U_p	≤ 1.5 kV
Residual voltage U_{res}	≤ 1.5 kV (at I_n)
	≤ 1.3 kV (at 10 kA)
	≤ 1.2 kV (at 5 kA)
	≤ 1.1 kV (at 4 kA)
	≤ 1 kV (at 2 kA)
TOV behavior at U_T	415 V AC (5 s / withstand mode)
	440 V AC (120 min / safe failure mode)
Response time t_A	≤ 25 ns
Max. backup fuse with branch wiring	315 A (gG)

Type 2 surge protection plug - VAL-CP-350-ST - 2859602

Technical data

Connection data

Connection method	pluggable
-------------------	-----------

UL specifications

SPD Type	4CA
Maximum continuous operating voltage MCOV (L-N)	350 V AC
Nom. voltage	277 V AC
Mode of protection	L-N
Power distribution system	Single phase
Nominal frequency	50/60 Hz
Measured limiting voltage MLV (L-N)	2000 V
Nominal discharge current I_n (L-N)	20 kA

Environmental Product Compliance

China RoHS	Environmentally friendly use period: unlimited = EFUP-e
	No hazardous substances above threshold values

Drawings

Type 2 surge protection plug - VAL-CP-350-ST - 2859602

Circuit diagram



Type 2 surge protection plug - VAL-CP-350-ST - 2859602

Dimensional drawing

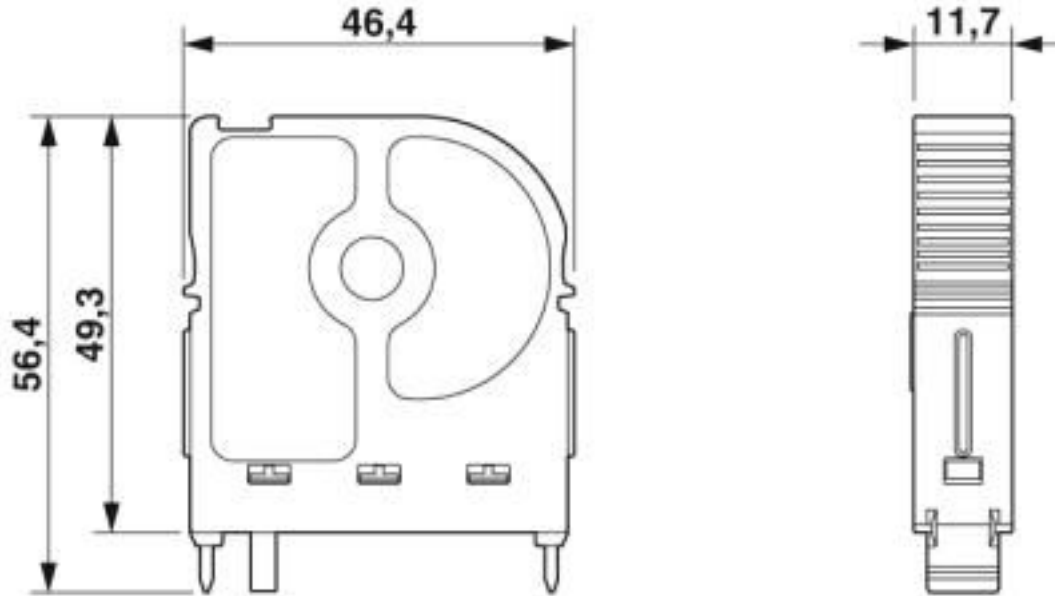

Classifications

eCl@ss

eCl@ss 10.0.1	27130890
eCl@ss 4.0	27130800
eCl@ss 4.1	27130800
eCl@ss 5.0	27130800
eCl@ss 5.1	27130800
eCl@ss 6.0	27130800
eCl@ss 7.0	27130805
eCl@ss 8.0	27130890
eCl@ss 9.0	27130890

ETIM

ETIM 2.0	EC000941
ETIM 3.0	EC000941
ETIM 4.0	EC000941
ETIM 5.0	EC002496
ETIM 6.0	EC000941
ETIM 7.0	EC000941

Type 2 surge protection plug - VAL-CP-350-ST - 2859602

Classifications

UNSPSC

UNSPSC 6.01	30212010
UNSPSC 7.0901	39121610
UNSPSC 11	39121610
UNSPSC 12.01	39121610
UNSPSC 13.2	39121620
UNSPSC 18.0	39121620
UNSPSC 19.0	39121620
UNSPSC 20.0	39121620
UNSPSC 21.0	39121620

Approvals

Approvals

Approvals

CCA / UL Recognized / KEMA-KEUR / cUL Recognized / IECCEB Scheme / EAC / EAC / cULus Recognized

Ex Approvals

Approval details

CCA	NTR-NL 7221
-----	-------------

UL Recognized		http://database.ul.com/cgi-bin/XYV/template/LISEXT/1FRAME/index.htm	FILE E 330181
---------------	---	---	---------------

KEMA-KEUR		http://www.dekra-certification.com	2161502.01
-----------	---	---	------------

cUL Recognized		http://database.ul.com/cgi-bin/XYV/template/LISEXT/1FRAME/index.htm	FILE E 330181
----------------	---	---	---------------

Type 2 surge protection plug - VAL-CP-350-ST - 2859602

Approvals

IECEE CB Scheme		http://www.iecee.org/	NL-29957
-----------------	---	---	----------

EAC			EAC-Zulassung
-----	---	--	---------------

EAC			RU C- DE.A*30.B01561
-----	---	--	-------------------------

cULus Recognized			
------------------	---	--	--

Accessories

Accessories

Device marking

Zack marker strip - ZBN 18:UNBEDRUCKT - 2809128



Zack marker strip, Strip, white, unlabeled, can be labeled with: CMS-P1-PLOTTER, PLOTMARK, mounting type: snap into tall marker groove, for terminal block width: 18 mm, lettering field size: 18 x 5 mm, Number of individual labels: 5

Labeled device marker

Marker for terminal blocks - ZBN 18,LGS:ERDE - 2749589



Marker for terminal blocks, Strip, white, labeled, horizontal: Grounding symbol, mounting type: snap into tall marker groove, for terminal block width: 18 mm, lettering field size: 18 x 5 mm, Number of individual labels: 5

Type 2 surge protection plug - VAL-CP-350-ST - 2859602

Accessories

Marker for terminal blocks - ZBN 18,LGS:L1-N,ERDE - 2749576



Marker for terminal blocks, Strip, white, labeled, horizontal: L1, L2, L3, N, GND, mounting type: snap into tall marker groove, for terminal block width: 18 mm, lettering field size: 18 x 5 mm, Number of individual labels: 5

Marker pen

Marker pen - B-STIFT - 1051993



Marker pen, for manual labeling of unprinted Zack strips, smear-proof and waterproof, line thickness 0.5 mm