

Type 2 surge arrester - VAL-MS 320/3+1/FM - 2859181

Please be informed that the data shown in this PDF Document is generated from our Online Catalog. Please find the complete data in the user's documentation. Our General Terms of Use for Downloads are valid (<http://phoenixcontact.com/download>)



Surge voltage arrester combination 4-channel, for mounting on NS 35/7.5, with remote indicator contact as PDT, voltage 230 V AC

Your advantages

- ✓ With or without floating remote indication contact
- ✓ Optical, mechanical status indication for the individual arresters
- ✓ Disconnect device on each individual plug
- ✓ Mechanical coding of all slots
- ✓ Multi-channel type 2 arresters
- ✓ Type 2 consistent plug-in surge arresters



Key Commercial Data

Packing unit	1 pc
GTIN	 4 017918 911218
GTIN	4017918911218
Weight per Piece (excluding packing)	400.000 g
Custom tariff number	85363030
Country of origin	Germany

Technical data

Dimensions

Height	98.7 mm
Width	71 mm
Depth	65.7 mm (incl. DIN rail 7.5 mm)
Horizontal pitch	4 Div.

Type 2 surge arrester - VAL-MS 320/3+1/FM - 2859181

Technical data

Ambient conditions

Degree of protection	IP20 (only when all terminal points are used)
Ambient temperature (operation)	-40 °C ... 80 °C
Ambient temperature (storage/transport)	-40 °C ... 80 °C
Altitude	≤ 2000 m (amsl (above mean sea level))
Permissible humidity (operation)	5 % ... 95 %
Shock (operation)	25g (Half-sine / 11 ms / 3x ±X, ±Y, ±Z)
Vibration (operation)	5g (10 ... 500 Hz / 2.5 h / X, Y, Z)

General

IEC test classification	II
	T2
EN type	T2
IEC power supply system	TN-S
	TT
Mode of protection	L-N
	L-PE
	N-PE
Mounting type	DIN rail: 35 mm
Color	jet black RAL 9005
Housing material	PA 6.6
	PBT
Degree of pollution	2
Flammability rating according to UL 94	V-0
Type	DIN rail module, two-section, divisible
Number of positions	4
Surge protection fault message	Optical, remote indicator contact

Protective circuit

Nominal voltage U_N	240/415 V AC (TN-S)
	240/415 V AC (TT)
Nominal frequency f_N	50 Hz (60 Hz)
Maximum continuous operating voltage U_C (L-N)	335 V AC
Maximum continuous operating voltage U_C (L-PE)	335 V AC
Maximum continuous voltage U_C (N-PE)	260 V AC
Rated load current I_L	80 A
Residual current I_{PE}	≤ 5 μA
Standby power consumption P_C	≤ 450 mVA
Nominal discharge current I_n (8/20) μs	20 kA

Type 2 surge arrester - VAL-MS 320/3+1/FM - 2859181

Technical data

Protective circuit

Maximum discharge current I_{max} (8/20) μ s	40 kA
Follow current interrupt rating I_{fi} (N-PE)	100 A
Short-circuit current rating I_{SCCR}	25 kA
Voltage protection level U_p (L-N)	≤ 1.5 kV
Voltage protection level U_p (L-PE)	≤ 1.9 kV
Voltage protection level U_p (N-PE)	≤ 1.5 kV
Residual voltage U_{res} (L-N)	≤ 1.5 kV (at I_n)
	≤ 1.3 kV (at 10 kA)
	≤ 1.2 kV (at 5 kA)
	≤ 1.1 kV (at 3 kA)
Residual voltage U_{res} (L-PE)	≤ 1.9 kV (at I_n)
	≤ 1.5 kV (at 10 kA)
	≤ 1.3 kV (at 5 kA)
	≤ 1.2 kV (at 3 kA)
Residual voltage U_{res} (N-PE)	≤ 0.4 kV (at I_n)
	≤ 0.25 kV (at 10 kA)
	≤ 0.15 kV (at 5 kA)
	≤ 0.1 kV (at 3 kA)
TOV behavior at U_T (L-N)	415 V AC (5 s / withstand mode)
	440 V AC (120 min / safe failure mode)
TOV behavior at U_T (N-PE)	1200 V AC (200 ms / withstand mode)
Response time t_A (L-N)	≤ 25 ns
Response time t_A (L-PE)	≤ 100 ns
Response time t_A (N-PE)	≤ 100 ns
Max. backup fuse with V-type through wiring	80 A (gG)
Max. backup fuse with branch wiring	125 A (gG)

Indicator/remote signaling

Switching function	PDT contact
Operating voltage	5 V AC ... 250 V AC
	30 V DC
Operating current	5 mA AC ... 750 mA AC
	1 A DC
Connection method	Plug-in/screw connection via COMBICON
Screw thread	M2
Tightening torque	0.25 Nm
Stripping length	7 mm

Type 2 surge arrester - VAL-MS 320/3+1/FM - 2859181

Technical data

Indicator/remote signaling

Conductor cross section flexible	0.14 mm ² ... 1.5 mm ²
Conductor cross section solid	0.14 mm ² ... 1.5 mm ²
Conductor cross section AWG	28 ... 16

Connection data

Connection method	Screw connection
Screw thread	M5
Tightening torque	3 Nm (1.5 mm ² ... 16 mm ²)
	4.5 Nm (25 mm ² ... 35 mm ²)
Stripping length	16 mm
Conductor cross section flexible	1.5 mm ² ... 25 mm ²
Conductor cross section solid	1.5 mm ² ... 35 mm ²
Conductor cross section AWG	15 ... 2
Connection method	Fork-type cable lug
Conductor cross section flexible	1.5 mm ² ... 16 mm ²

UL specifications

SPD Type	4CA
Maximum continuous operating voltage MCOV (L-L)	640 V AC
Maximum continuous operating voltage MCOV (L-N)	320 V AC
Maximum continuous operating voltage MCOV (L-G)	320 V AC
Maximum continuous operating voltage MCOV (N-G)	260 V AC
Nom. voltage	240/415 V AC
Mode of protection	L-L
	L-N
	L-G
	N-G
Power distribution system	Wye
Nominal frequency	50/60 Hz
Measured limiting voltage MLV (L-L)	2900 V
Measured limiting voltage MLV (L-N)	2030 V
Measured limiting voltage MLV (L-G)	2720 V
Measured limiting voltage MLV (N-G)	1370 V
Nominal discharge current I _n (L-L)	20 kA
Nominal discharge current I _n (L-N)	20 kA
Nominal discharge current I _n (L-G)	20 kA
Nominal discharge current I _n (N-G)	20 kA

UL indicator/remote signaling

Type 2 surge arrester - VAL-MS 320/3+1/FM - 2859181

Technical data

UL indicator/remote signaling

Operating voltage	125 V AC
Operating current	1 A AC
Tightening torque	4 lb _F -in.
Conductor cross section AWG	30 ... 14

UL connection data

Conductor cross section AWG	10 ... 2
Tightening torque	30 lb _F -in.

Standards and Regulations

Standards/regulations	IEC 61643-11 2011
	EN 61643-11 2012

Environmental Product Compliance

REACH SVHC	Lead 7439-92-1
China RoHS	Environmentally Friendly Use Period = 50 years
	For details about hazardous substances go to tab "Downloads", Category "Manufacturer's declaration"

Drawings

Dimensional drawing

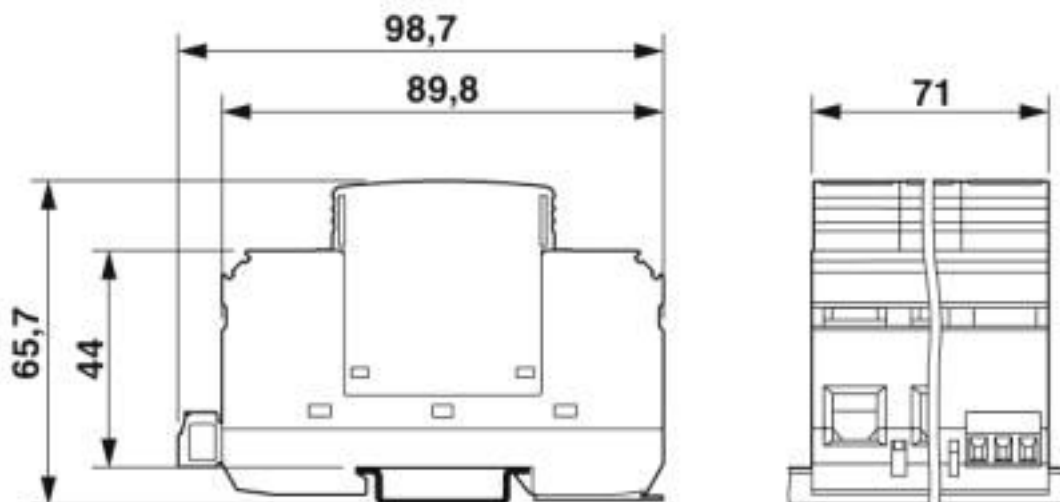

Type 2 surge arrester - VAL-MS 320/3+1/FM - 2859181

Circuit diagram

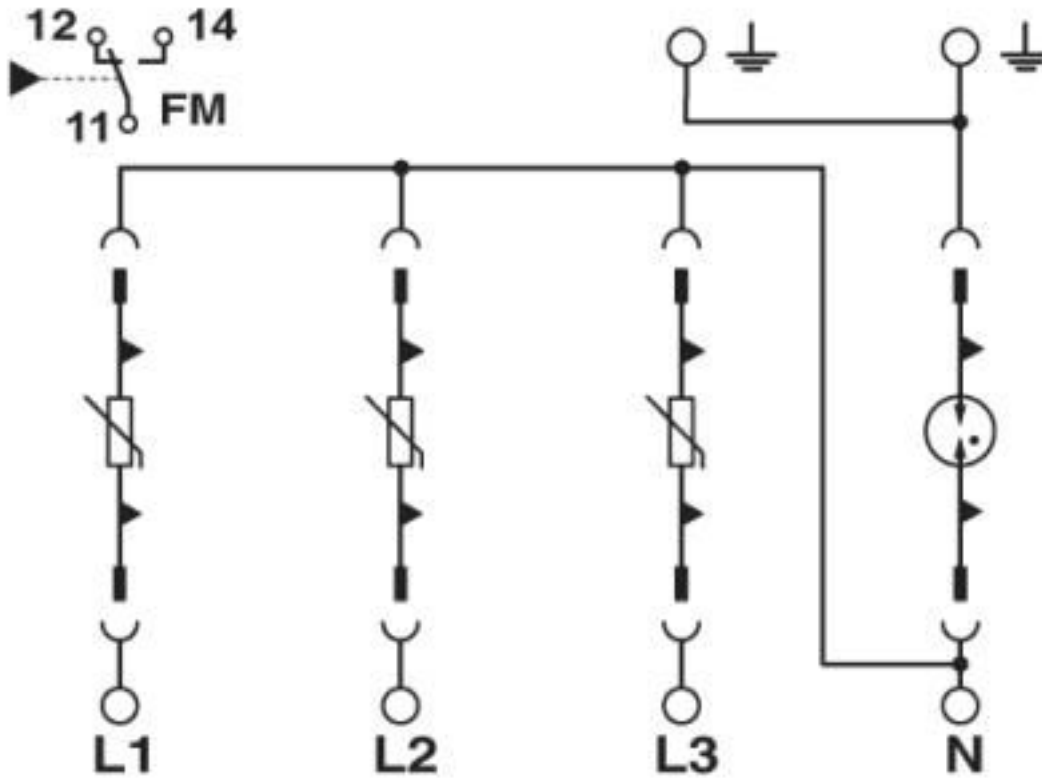

Classifications

eCl@ss

eCl@ss 10.0.1	27130805
eCl@ss 4.0	27130800
eCl@ss 4.1	27130800
eCl@ss 5.0	27130800
eCl@ss 5.1	27130800
eCl@ss 6.0	27130800
eCl@ss 7.0	27130805
eCl@ss 8.0	27130805
eCl@ss 9.0	27130805

ETIM

ETIM 2.0	EC000941
ETIM 3.0	EC000941
ETIM 4.0	EC000941

Type 2 surge arrester - VAL-MS 320/3+1/FM - 2859181

Classifications

ETIM

ETIM 5.0	EC000941
ETIM 6.0	EC000941
ETIM 7.0	EC000941

UNSPSC

UNSPSC 6.01	30212010
UNSPSC 7.0901	39121610
UNSPSC 11	39121610
UNSPSC 12.01	39121610
UNSPSC 13.2	39121620
UNSPSC 18.0	39121620
UNSPSC 19.0	39121620
UNSPSC 20.0	39121620
UNSPSC 21.0	39121620

Approvals

Approvals

Approvals

CSA / GL / CCA / UL Recognized / KEMA-KEUR / cUL Recognized / IECCE CB Scheme / ÖVE / EAC / cULus Recognized

Ex Approvals

Approval details

CSA		http://www.csagroup.org/services-industries/product-listing/	13631
-----	--	---	-------

GL		https://approvalfinder.dnvgl.com/	94385-10 HH
----	--	---	-------------

CCA	NTR-AT 1947-A		
-----	---------------	--	--

Type 2 surge arrester - VAL-MS 320/3+1/FM - 2859181

Approvals

UL Recognized		http://database.ul.com/cgi-bin/XYV/template/LISEXT/1FRAME/index.htm	FILE E 330181
KEMA-KEUR		http://www.dekra-certification.com	71-113273
cUL Recognized		http://database.ul.com/cgi-bin/XYV/template/LISEXT/1FRAME/index.htm	FILE E 330181
IECEE CB Scheme		http://www.iecee.org/	AT 2905/M1
ÖVE		https://www.ove.at/zertifizierung-pz/zertifizierungsregister/	18583-001-14
EAC			RU C- DE.A*30.B01561
cULus Recognized			

Accessories

Accessories

Bridge

Wiring bridge - MPB 18/4- 8 - 2809283



Wiring bridge for modules with connecting pitch 17.5 mm, 4-phase, 8-pos.

Type 2 surge arrester - VAL-MS 320/3+1/FM - 2859181

Accessories

Device marking

Zack marker strip - ZBN 18:UNBEDRUCKT - 2809128



Zack marker strip, Strip, white, unlabeled, can be labeled with: CMS-P1-PLOTTER, PLOTMARK, mounting type: snap into tall marker groove, for terminal block width: 18 mm, lettering field size: 18 x 5 mm, Number of individual labels: 5

Feed-through terminal block

Feed-through terminal block - DK-BIC-35 - 2749880



Feed-through terminal block for VAL and FLT applications

Labeled device marker

Marker for terminal blocks - ZBN 18,LGS:ERDE - 2749589



Marker for terminal blocks, Strip, white, labeled, horizontal: Grounding symbol, mounting type: snap into tall marker groove, for terminal block width: 18 mm, lettering field size: 18 x 5 mm, Number of individual labels: 5

Marker for terminal blocks - ZBN 18,LGS:L1-N,ERDE - 2749576



Marker for terminal blocks, Strip, white, labeled, horizontal: L1, L2, L3, N, GND, mounting type: snap into tall marker groove, for terminal block width: 18 mm, lettering field size: 18 x 5 mm, Number of individual labels: 5

Marker pen

Type 2 surge arrester - VAL-MS 320/3+1/FM - 2859181

Accessories

Marker pen - B-STIFT - 1051993



Marker pen, for manual labeling of unprinted Zack strips, smear-proof and waterproof, line thickness 0.5 mm

Spare parts

Type 2 surge protection plug - VAL-MS 320 ST - 2838843



Surge protection connector type 2 with high-capacity varistor for VAL-MS base element, thermal monitoring, visual fault warning. Design: 320 V AC

Type 2 surge protection plug - F-MS 12 ST - 2817990



Surge protection plug type 2, with N-PE total current spark gap for base element.
