

Type 2 surge arrester - VAL-MS 350VF - 2856582

Please be informed that the data shown in this PDF Document is generated from our Online Catalog. Please find the complete data in the user's documentation. Our General Terms of Use for Downloads are valid (<http://phoenixcontact.com/download>)



Surge voltage arrester consisting of base element with protective plug with a connection in series with a varistor and a gas-filled spark gap, for mounting on NS 35/7.5, nominal voltage: 230 V AC, 1-channel

Your advantages

- ✓ Single-channel, DIN-rail mountable protective devices
- ✓ Base element with/without floating remote indication contact
- ✓ Disconnect device on each individual plug
- ✓ Optical, mechanical status indication for the individual arresters
- ✓ Mechanical coding of all slots
- ✓ Consists of base element and plug

RoHS

Key Commercial Data

Packing unit	1 pc
GTIN	
GTIN	4017918876845
Weight per Piece (excluding packing)	129.700 g
Custom tariff number	85363030
Country of origin	Germany

Technical data

Dimensions

Height	89.8 mm
Width	17.6 mm
Depth	65.7 mm (incl. DIN rail 7.5 mm)
Horizontal pitch	1 Div.

Type 2 surge arrester - VAL-MS 350VF - 2856582

Technical data

Ambient conditions

Degree of protection	IP20 (only when all terminal points are used)
Ambient temperature (operation)	-40 °C ... 80 °C
Ambient temperature (storage/transport)	-40 °C ... 80 °C
Altitude	≤ 2000 m (amsl (above mean sea level))
Permissible humidity (operation)	5 % ... 95 %
Shock (operation)	25g (Half-sine / 11 ms / 3x ±X, ±Y, ±Z)
Vibration (operation)	5g (10 ... 500 Hz / 2.5 h / X, Y, Z)

General

IEC test classification	II
	T2
EN type	T2
IEC power supply system	TN
	TT
	IT
Mode of protection	L-N
	L-PE
	L-PEN
Mounting type	DIN rail: 35 mm
Color	jet black RAL 9005
Housing material	PA 6.6
	PBT
Degree of pollution	2
Flammability rating according to UL 94	V-0
Type	DIN rail module, two-section, divisible
Number of positions	1
Surge protection fault message	optical

Additional descriptions

Note	Usable in all low-voltage systems between L-N or L-PEN. Only usable in IT Systems between L-PE, if the exposed-conductive-parts (bodies) of the equipment of the low-voltage installation is connected to the earthing arrangement of the transformer substation. (interconnected earthing arrangement of the HV-transformer substation with the bodies of the LV-installation. $R_E = R_A$ accordance to IEC 60364-4-442 / VDE 0100-442 Fig. 44D / Example a)
------	---

Protective circuit

Nominal voltage U_N	240/415 V AC (TN)
	240/415 V AC (TT)
	230 V AC (IT)

Type 2 surge arrester - VAL-MS 350VF - 2856582

Technical data

Protective circuit

Nominal frequency f_N	50 Hz (60 Hz)
Maximum continuous voltage U_C	350 V AC
Rated load current I_L	80 A
Residual current I_{PE}	$\leq 5 \mu A$
Standby power consumption P_C	$\leq 2 \text{ mVA}$
Nominal discharge current I_n (8/20) μs	10 kA
Maximum discharge current I_{max} (8/20) μs	20 kA
Short-circuit current rating I_{SCCR}	25 kA
Voltage protection level U_p	$\leq 1.5 \text{ kV}$
Residual voltage U_{res}	$\leq 1.2 \text{ kV}$ (at I_n)
	$\leq 1.2 \text{ kV}$ (at 10 kA)
	$\leq 1.1 \text{ kV}$ (at 5 kA)
Front of wave sparkover voltage at 6 kV (1.2/50) μs	$\leq 1.5 \text{ kV}$
TOV behavior at U_T	415 V AC (5 s / withstand mode)
	440 V AC (120 min / withstand mode)
Response time t_A	$\leq 100 \text{ ns}$
Max. backup fuse with V-type through wiring	80 A (gG)
Max. backup fuse with branch wiring	125 A (gG)

Connection data

Connection method	Screw connection
Screw thread	M5
Tightening torque	3 Nm (1.5 mm ² ... 16 mm ²)
	4.5 Nm (25 mm ² ... 35 mm ²)
Stripping length	16 mm
Conductor cross section flexible	1.5 mm ² ... 25 mm ²
Conductor cross section solid	1.5 mm ² ... 35 mm ²
Conductor cross section AWG	15 ... 2
Connection method	Fork-type cable lug
Conductor cross section flexible	1.5 mm ² ... 16 mm ²

UL specifications

SPD Type	4CA
Maximum continuous operating voltage MCOV (L-N)	350 V AC
Nom. voltage	240 V AC
Mode of protection	L-N
Power distribution system	Single phase
Nominal frequency	50/60 Hz

Type 2 surge arrester - VAL-MS 350VF - 2856582

Technical data

UL specifications

Measured limiting voltage MLV (L-N)	2420 V
Nominal discharge current I_n (L-N)	10 kA

UL connection data

Conductor cross section AWG	10 ... 2
Tightening torque	30 lb _f -in.

Standards and Regulations

Standards/regulations	IEC 61643-11 2011
	EN 61643-11 2012

Environmental Product Compliance

China RoHS	Environmentally friendly use period: unlimited = EFUP-e
	No hazardous substances above threshold values

Drawings

Type 2 surge arrester - VAL-MS 350VF - 2856582

Circuit diagram

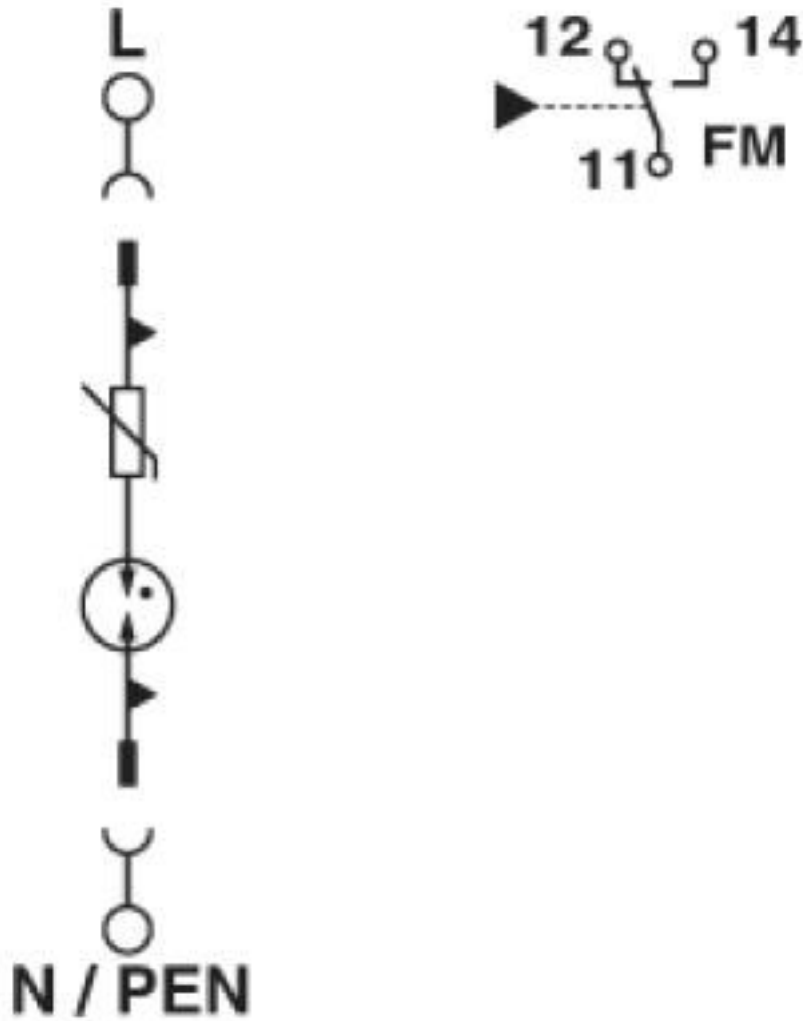
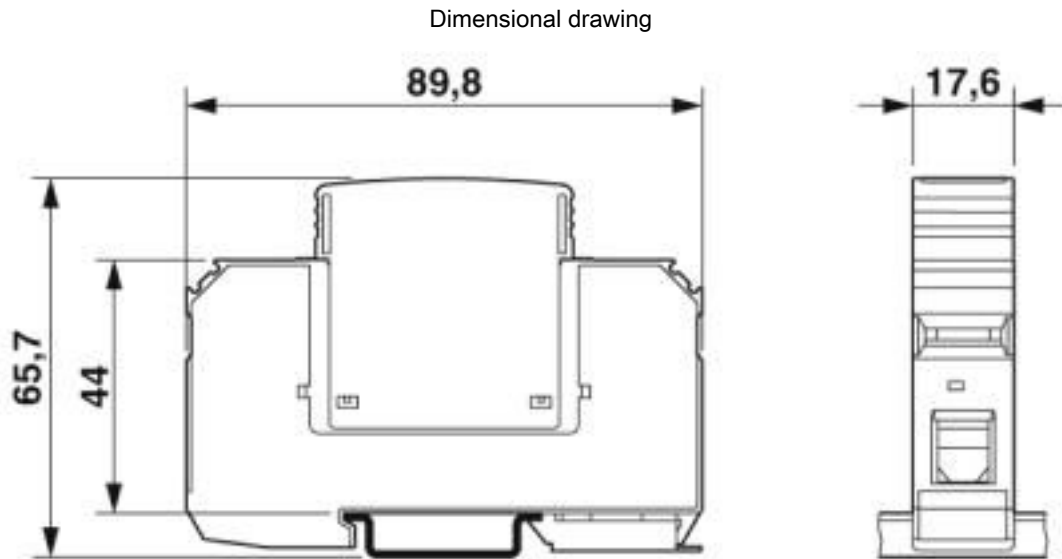

Figure shows version with remote indication contact

Type 2 surge arrester - VAL-MS 350VF - 2856582



Classifications

eCl@ss

eCl@ss 10.0.1	27130805
eCl@ss 4.0	27130800
eCl@ss 4.1	27130800
eCl@ss 5.0	27130800
eCl@ss 5.1	27130800
eCl@ss 6.0	27130800
eCl@ss 7.0	27130805
eCl@ss 8.0	27130805
eCl@ss 9.0	27130805

ETIM

ETIM 2.0	EC000941
ETIM 3.0	EC000941
ETIM 4.0	EC000941
ETIM 5.0	EC000941
ETIM 6.0	EC000941
ETIM 7.0	EC000941

UNSPSC

UNSPSC 6.01	30212010
UNSPSC 7.0901	39121610
UNSPSC 11	39121610

Type 2 surge arrester - VAL-MS 350VF - 2856582

Classifications

UNSPSC

UNSPSC 12.01	39121610
UNSPSC 13.2	39121620
UNSPSC 18.0	39121620
UNSPSC 19.0	39121620
UNSPSC 20.0	39121620
UNSPSC 21.0	39121620

Approvals

Approvals

Approvals

CSA / CCA / UL Recognized / KEMA-KEUR / cUL Recognized / IEC EE CB Scheme / ÖVE / EAC / EAC / cULus Recognized

Ex Approvals

Approval details

CSA		http://www.csagroup.org/services-industries/product-listing/	13631
CCA			NTR-AT 1947-A
UL Recognized		http://database.ul.com/cgi-bin/XYV/template/LISEXT/1FRAME/index.htm	FILE E 330181
KEMA-KEUR		http://www.dekra-certification.com	71-113273
cUL Recognized		http://database.ul.com/cgi-bin/XYV/template/LISEXT/1FRAME/index.htm	FILE E 330181

Type 2 surge arrester - VAL-MS 350VF - 2856582

Approvals

IECEE CB Scheme		http://www.iecee.org/	AT 2905/M1
ÖVE		https://www.ove.at/zertifizierung-pz/zertifizierungsregister/	18583-001-14
EAC			EAC-Zulassung
EAC			RU C- DE.A*30.B01561
cULus Recognized			

Accessories

Accessories

Bridge

Wiring bridge - MPB 18/1- 2 - 2809209



Wiring bridge for modules with connecting pitch 17.5 mm, 1-phase, 2-pos.

Wiring bridge - MPB 18/1- 3 - 2809212



Wiring bridge for modules with connecting pitch 17.5 mm, 1-phase, 3-pos.

Type 2 surge arrester - VAL-MS 350VF - 2856582

Accessories

Wiring bridge - MPB 18/1- 4 - 2809225



Wiring bridge for modules with connecting pitch 17.5 mm, 1-phase, 4-pos.

Wiring bridge - MPB 18/1- 6 - 2748564



Wiring bridge for modules with connecting pitch 17.5 mm, 1-phase, 6-pos.

Wiring bridge - MPB 18/1- 7 BU - 2856278



Wiring bridge for modules with connecting pitch 17.5 mm, 1-phase, 7-pos., color: Blue

Wiring bridge - MPB 18/1- 8 BU - 2858470



Wiring bridge for modules with connecting pitch 17.5 mm, 1-phase, 8-pos., color: Blue

Wiring bridge - MPB 18/1- 8 - 2748577



Wiring bridge for modules with connecting pitch 17.5 mm, 1-phase, 8-pos.

Type 2 surge arrester - VAL-MS 350VF - 2856582

Accessories

Wiring bridge - MPB 18/1- 9 - 2748580



Wiring bridge for modules with connecting pitch 17.5 mm, 1-phase, 9-pos.

Wiring bridge - MPB 18/1-12 - 2748593



Wiring bridge for modules with connecting pitch 17.5 mm, 1-phase, 12-pos.

Wiring bridge - MPB 18/1-57 - 2809238



Wiring bridge for modules with connecting pitch 17.5 mm, 1-phase, 57-pos.

Wiring bridge - MPB 18/3- 6 - 2809241



Wiring bridge for modules with connecting pitch 17.5 mm, 3-phase, 6-pos.

Wiring bridge - MPB 18/4- 8 - 2809283



Wiring bridge for modules with connecting pitch 17.5 mm, 4-phase, 8-pos.

Device marking

Type 2 surge arrester - VAL-MS 350VF - 2856582

Accessories

Zack marker strip - ZBN 18:UNBEDRUCKT - 2809128



Zack marker strip, Strip, white, unlabeled, can be labeled with: CMS-P1-PLOTTER, PLOTMARK, mounting type: snap into tall marker groove, for terminal block width: 18 mm, lettering field size: 18 x 5 mm, Number of individual labels: 5

Feed-through terminal block

Feed-through terminal block - DK-BIC-35 - 2749880



Feed-through terminal block for VAL and FLT applications

Labeled device marker

Marker for terminal blocks - ZBN 18,LGS:ERDE - 2749589



Marker for terminal blocks, Strip, white, labeled, horizontal: Grounding symbol, mounting type: snap into tall marker groove, for terminal block width: 18 mm, lettering field size: 18 x 5 mm, Number of individual labels: 5

Marker for terminal blocks - ZBN 18,LGS:L1-N,ERDE - 2749576



Marker for terminal blocks, Strip, white, labeled, horizontal: L1, L2, L3, N, GND, mounting type: snap into tall marker groove, for terminal block width: 18 mm, lettering field size: 18 x 5 mm, Number of individual labels: 5

Marker pen

Type 2 surge arrester - VAL-MS 350VF - 2856582

Accessories

Marker pen - B-STIFT - 1051993



Marker pen, for manual labeling of unprinted Zack strips, smear-proof and waterproof, line thickness 0.5 mm

Replacement plug

Type 2 surge protection plug - VAL-MS 350 VF ST - 2856595



Surge protection connector type 2 with series connection consisting of varistor and gas-filled spark gap for VAL-MS base element, thermal monitoring, visual fault warning. Design: 350 V AC

Spare parts

Type 2 surge protection plug - VAL-MS 350 VF ST - 2856595



Surge protection connector type 2 with series connection consisting of varistor and gas-filled spark gap for VAL-MS base element, thermal monitoring, visual fault warning. Design: 350 V AC