

Surge protection plug - PT 2X1VA- 60AC-ST - 2839172

Please be informed that the data shown in this PDF Document is generated from our Online Catalog. Please find the complete data in the user's documentation. Our General Terms of Use for Downloads are valid (<http://phoenixcontact.com/download>)



Protective plug PT with protective circuit for higher signal voltages, 2-channel, visual error display. Nominal voltage: 60 V AC

Your advantages

- ✓ Plugs can be checked with CHECKMASTER
- ✓ Maximum ease of maintenance thanks to the two-piece design
- ✓ Base element remains an integral part of the installation
- ✓ Consistent plug-in signal circuit protection
- ✓ Protective devices for use in telecommunications and signaling networks according to IEC 61643-21
- ✓ Impedance-neutral disconnection of plug for test and maintenance purposes



Key Commercial Data

Packing unit	1 pc
GTIN	 4 017918 182830
GTIN	4017918182830
Weight per Piece (excluding packing)	27.010 g
Custom tariff number	85363010
Country of origin	Germany

Technical data

Dimensions

Height	44.8 mm
Width	17.5 mm
Depth	51.7 mm
Horizontal pitch	1 Div.

Surge protection plug - PT 2X1VA- 60AC-ST - 2839172

Technical data

Dimensions

Complete module height	90 mm
Complete module width	17.7 mm
Complete module depth	65.5 mm

Ambient conditions

Ambient temperature (operation)	-40 °C ... 85 °C
Ambient temperature (storage/transport)	-40 °C ... 85 °C
Altitude	≤ 2000 m (amsl (above mean sea level))
Degree of protection	IP20

General

Housing material	PA 6.6
Flammability rating according to UL 94	V-0
Color	jet black RAL 9005
Mounting type	on base element
Type	Male
Direction of action	Line-Line & Line-Earth Ground
Arrester can be tested with CHECKMASTER from software version:	From SW rev. 1.00

Additional descriptions

Note	Technical data is valid in association with the following specified base elements:
	PT -BE/ FM 2839282

Protective circuit

IEC test classification	C1
	C2
	C3
	D1
Nominal voltage U_N	60 V AC
Maximum continuous voltage U_C	100 V DC
	75 V AC (50/60 Hz)
Rated current	26 A AC (30 °C)
	3 A DC (78 °C)
Operating effective current I_C at U_C	≤ 1.5 mA AC
	≤ 3 mA DC
Residual current I_{PE}	≤ 3 mA AC
	≤ 6 mA DC
Nominal discharge current I_n (8/20) μ s (line-earth)	2 kA
Pulse discharge current I_{imp} (10/350) μ s	500 A

Surge protection plug - PT 2X1VA- 60AC-ST - 2839172

Technical data

Protective circuit

Total discharge current $I_{total} (8/20) \mu s$	4 kA
Output voltage limitation at 1 kV/ μs (line-earth) spike	$\leq 200 V$
Output voltage limitation at 1 kV/ μs (line-earth) static	$\leq 200 V$
Voltage protection level U_p (line-earth)	$\leq 250 V$ (C1 - 1.4 kV / 0.7 kA)
	$\leq 300 V$ (C2 - 4 kV / 2 kA)
	$\leq 220 V$ (C3 - 100 A)
Response time t_A (line-earth)	$\leq 25 ns$
Input attenuation aE, asym.	typ. 0.3 dB ($\leq 150 kHz / 150 \Omega$)
Cut-off frequency f_g (3 dB), asym. (GND) in 150 Ohm system	typ. 600 kHz
Capacity (line-earth)	typ. 4 nF
Surge protection fault message	none
Max. required back-up fuse	25 A AC (gL/gG)
	3 A DC (T)
Impulse durability (line-earth)	C1 - 1,4 kV / 0,7 kA
	C2 - 4 kV / 2 kA
	C3 - 100 A
	D1 - 500 A

Connection data

Connection method	Screw connection (in connection with the base element)
Screw thread	M3
Tightening torque	0.5 Nm
Stripping length	8 mm
Conductor cross section flexible	0.2 mm ² ... 2.5 mm ²
Conductor cross section solid	0.2 mm ² ... 4 mm ²
Conductor cross section AWG	24 ... 12

Standards and Regulations

Standards/specifications	IEC 61643 2000 + corrigendum 2001 + A1:2008, modified + A2:2012
	EN 61643-21 2001 + A1:2009 + A2:2013

Environmental Product Compliance

REACH SVHC	Lead 7439-92-1
China RoHS	Environmentally Friendly Use Period = 50 years
	For details about hazardous substances go to tab "Downloads", Category "Manufacturer's declaration"

Drawings

Surge protection plug - PT 2X1VA- 60AC-ST - 2839172

Diagram

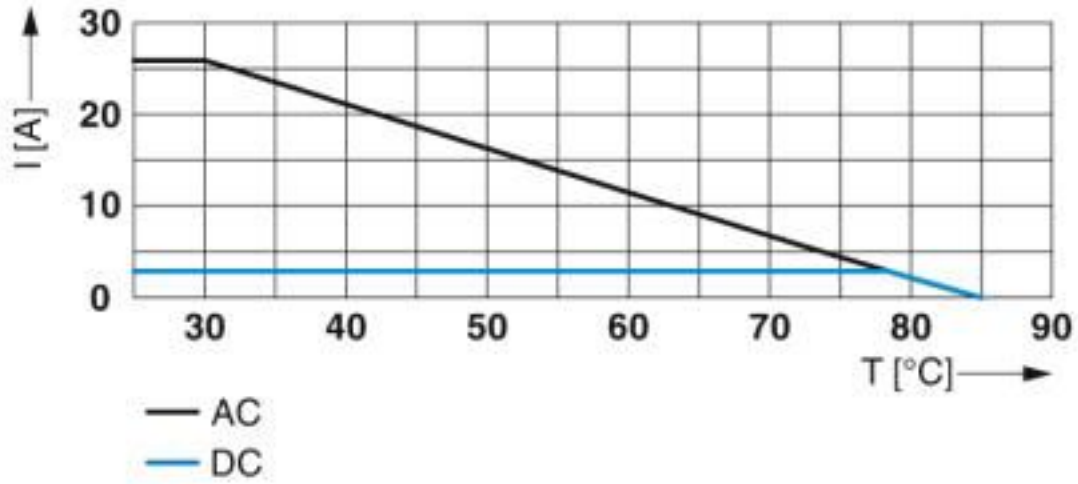

Dimensional drawing

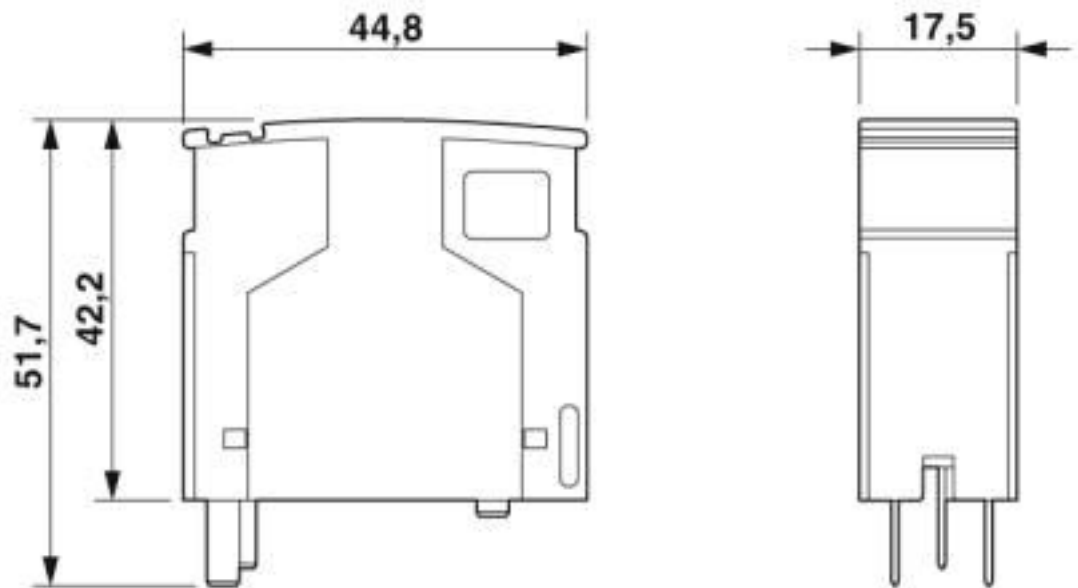

Surge protection plug - PT 2X1VA- 60AC-ST - 2839172

Dimensional drawing

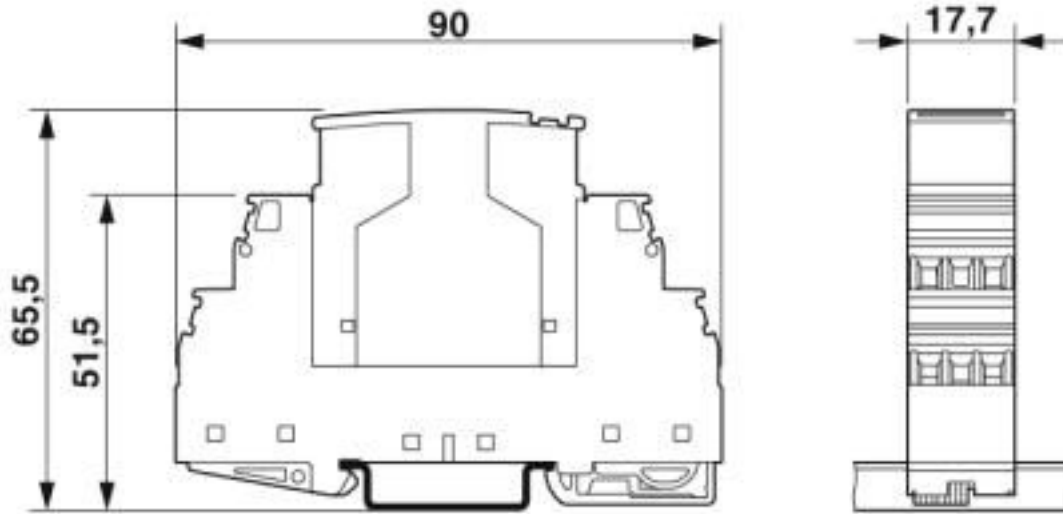

The figure shows the complete module consisting of a base element and connector

Pictogram

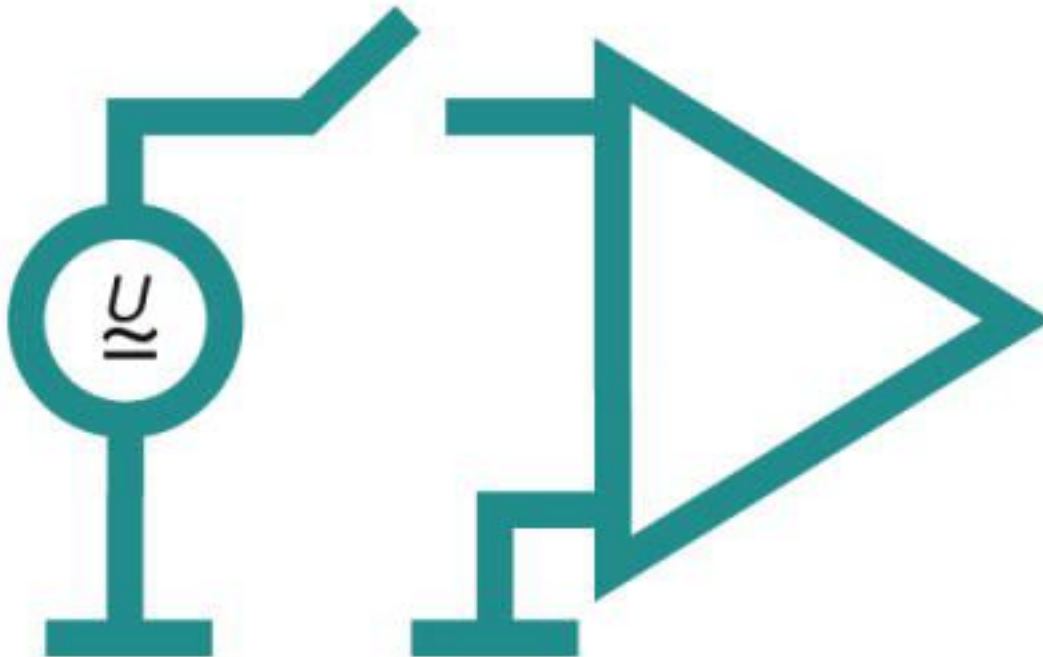

Surge protection plug - PT 2X1VA- 60AC-ST - 2839172

Circuit diagram

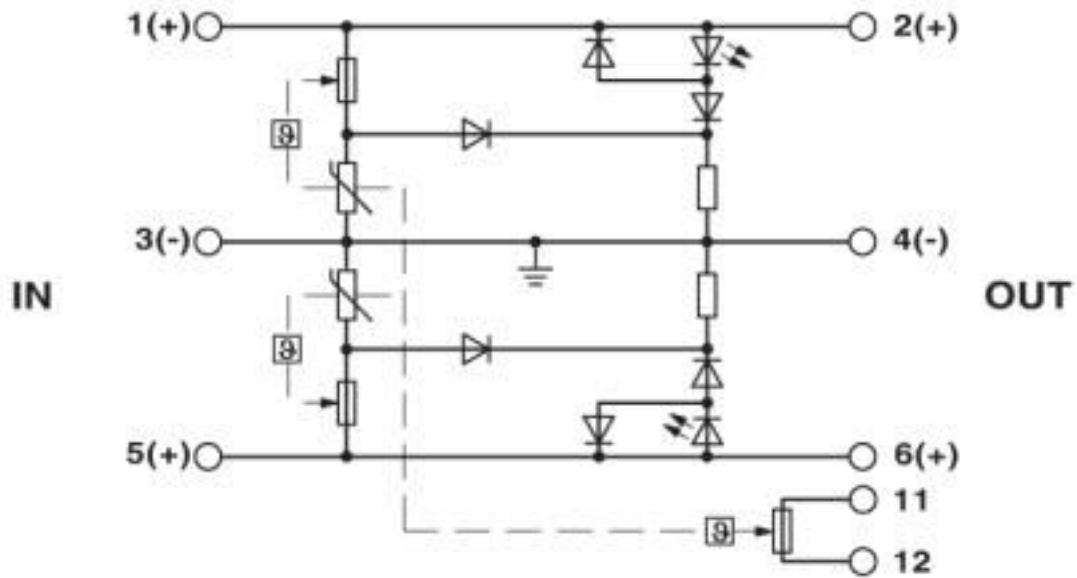

Classifications

eCl@ss

eCl@ss 10.0.1	27130807
eCl@ss 4.0	27130800
eCl@ss 4.1	27130800
eCl@ss 5.0	27130800
eCl@ss 5.1	27130800
eCl@ss 6.0	27130800
eCl@ss 7.0	27130807
eCl@ss 8.0	27130807
eCl@ss 9.0	27130807

ETIM

ETIM 2.0	EC000943
ETIM 3.0	EC000943
ETIM 4.0	EC000943
ETIM 5.0	EC000943
ETIM 6.0	EC000943
ETIM 7.0	EC000943

UNSPSC

UNSPSC 6.01	30212010
-------------	----------

Surge protection plug - PT 2X1VA- 60AC-ST - 2839172

Classifications

UNSPSC

UNSPSC 7.0901	39121610
UNSPSC 11	39121610
UNSPSC 12.01	39121610
UNSPSC 13.2	39121620
UNSPSC 18.0	39121620
UNSPSC 19.0	39121620
UNSPSC 20.0	39121620
UNSPSC 21.0	39121620

Approvals

Approvals

Approvals

UL Listed / EAC

Ex Approvals

Approval details

UL Listed		http://database.ul.com/cgi-bin/XYV/template/LISEXT/1FRAME/index.htm	FILE E 138168
-----------	--	---	---------------

EAC		RU C- DE.A*30.B01561
-----	--	-------------------------

Accessories

Accessories

Device marking

Surge protection plug - PT 2X1VA- 60AC-ST - 2839172

Accessories

Zack marker strip - ZBN 18:UNBEDRUCKT - 2809128



Zack marker strip, Strip, white, unlabeled, can be labeled with: CMS-P1-PLOTTER, PLOTMARK, mounting type: snap into tall marker groove, for terminal block width: 18 mm, lettering field size: 18 x 5 mm, Number of individual labels: 5

Labeled terminal marker

Zack Marker strip, flat - ZBF 5,LGS:FORTL.ZAHLEN - 0808671



Zack Marker strip, flat, Strip, white, labeled, printed horizontally: consecutive numbers 1 ... 10, 11 ... 20, etc. up to 491 ... 500, mounting type: snap into flat marker groove, for terminal block width: 5 mm, lettering field size: 5.15 x 5.15 mm, Number of individual labels: 10

Zack Marker strip, flat - ZBF 5,LGS:GERADE ZAHLEN - 0810821



Zack Marker strip, flat, Strip, white, labeled, printed horizontally: consecutive numbers 2 ... 20, 22 ... 40, etc. up to 82 ... 100, mounting type: snap into flat marker groove, for terminal block width: 5 mm, lettering field size: 5.15 x 5.15 mm, Number of individual labels: 10

Zack Marker strip, flat - ZBF 5,LGS:UNGERADE ZAHLEN - 0810863



Zack Marker strip, flat, Strip, white, labeled, printed horizontally: Odd numbers 1 - 19, 21 - 39, etc. up to 81 - 99, mounting type: snap into flat marker groove, for terminal block width: 5 mm, lettering field size: 5.15 x 5.15 mm, Number of individual labels: 10

Zack Marker strip, flat - ZBF 5,QR:FORTL.ZAHLEN - 0808697



Zack Marker strip, flat, Strip, white, labeled, Printed vertically: consecutive numbers 1 ... 10, 11 ... 20, etc. up to 91 ... 100, mounting type: snap into flat marker groove, for terminal block width: 5 mm, lettering field size: 5.15 x 5.15 mm, Number of individual labels: 10

Surge protection plug - PT 2X1VA- 60AC-ST - 2839172

Accessories

Marker pen

Marker pen - X-PEN 0,35 - 0811228



Marker pen without ink cartridge, for manual labeling of markers, labeling extremely wipe-proof, line thickness 0.35 mm

Terminal marking

Zack Marker strip, flat - ZBF 5:UNBEDRUCKT - 0808642



Zack Marker strip, flat, Strip, white, unlabeled, can be labeled with: PLOTMARK, CMS-P1-PLOTTER, mounting type: snap into flat marker groove, for terminal block width: 5 mm, lettering field size: 5.1 x 5.2 mm, Number of individual labels: 10

Zack Marker strip, flat - ZBF 5/WH-100:UNBEDRUCKT - 0808668



Zack Marker strip, flat, Strip, white, unlabeled, can be labeled with: CMS-P1-PLOTTER, PLOTMARK, mounting type: snap into flat marker groove, for terminal block width: 5 mm, lettering field size: 5.15 x 5.15 mm, Number of individual labels: 10

Necessary add-on products

Type 3 surge protection base element - PT-BE/FM - 2839282



Base element for protective plug PT, for mounting on NS 35/7.5 and NS 35/15, housing width: 17.5 mm

Additional products

Surge protection plug - PT 2X1VA- 60AC-ST - 2839172

Accessories

Shield connection - SSA 3-6 - 2839295



Shield fast connection for 3 ... 6 mm cable diameter. Potential connecting cable: 200 mm, 1 mm², color: black

Shield connection - SSA 5-10 - 2839512



Shield fast connection for 5 ... 10 mm cable diameter. Potential connecting cable: 200 mm, 1 mm², color: black
