

Surge protection plug - PT 2X2- 5DC-ST - 2838241

Please be informed that the data shown in this PDF Document is generated from our Online Catalog. Please find the complete data in the user's documentation. Our General Terms of Use for Downloads are valid (<http://phoenixcontact.com/download>)



PT protective connector with protective circuit for two 2-wire floating signal circuits. 5 V DC nominal voltage. HART-compatible.

Your advantages

- ✓ Plugs can be checked with CHECKMASTER
- ✓ Installed in conjunction with the PT 2x2...-BE base element
- ✓ Maximum ease of maintenance thanks to the two-piece design
- ✓ Base element remains an integral part of the installation
- ✓ Consistent plug-in signal circuit protection
- ✓ Protection for two separate floating signal circuits
- ✓ Impedance-neutral disconnection of plug for test and maintenance purposes



Key Commercial Data

Packing unit	1 pc
Minimum order quantity	10 pc
GTIN	 4 017918 182656
GTIN	4017918182656
Weight per Piece (excluding packing)	24.620 g
Custom tariff number	85363010
Country of origin	Germany

Technical data

Dimensions

Height	44.8 mm
Width	17.5 mm

Surge protection plug - PT 2X2- 5DC-ST - 2838241

Technical data

Dimensions

Depth	51.7 mm
Horizontal pitch	1 Div.
Complete module height	90 mm
Complete module width	17.7 mm
Complete module depth	65.5 mm

Ambient conditions

Ambient temperature (operation)	-40 °C ... 85 °C
Degree of protection	IP20

General

Housing material	PA 6.6
Flammability rating according to UL 94	V-0
Color	black
Standards for clearances and creepage distances	VDE 0110-1 IEC 60664-1
Mounting type	on base element
Type	Male
Direction of action	Line-Line & Line-Signal Ground/Shield & optional Signal Ground/Shield-Earth Ground
Arrester can be tested with CHECKMASTER from software version:	From SW rev. 1.00

Protective circuit

IEC test classification	C1 C2 C3 D1
Nominal voltage U_N	5 V DC
Maximum continuous voltage U_C	6 V DC 4 V AC
Rated current	450 mA (45 °C)
Operating effective current I_C at U_C	≤ 1 mA
Residual current I_{PE}	≤ 1 μ A (with PT 2X2+F-BE) ≤ 4 μ A
Nominal discharge current I_n (8/20) μ s (line-line)	10 kA
Nominal discharge current I_n (8/20) μ s (line-earth)	10 kA
Pulse discharge current I_{imp} (10/350) μ s	2.5 kA (per path)
Total discharge current I_{total} (8/20) μ s	20 kA
Max. discharge current I_{max} (8/20) μ s maximum (line-line)	10 kA

Surge protection plug - PT 2X2- 5DC-ST - 2838241

Technical data

Protective circuit

Max. discharge current I_{max} (8/20) μ s maximum (line-earth)	10 kA
Output voltage limitation at 1 kV/ μ s (line-line) spike	≤ 12 V
Output voltage limitation at 1 kV/ μ s (line-earth) spike	≤ 450 V
Output voltage limitation at 1 kV/ μ s (line-line) static	≤ 10 V
Residual voltage at I_n (line-line)	≤ 10 V
Residual voltage at I_n (line-signalground)	≤ 450 V
Residual voltage with I_{an} (10/1000) μ s (line-line)	≤ 12 V
Response time t_A (line-line)	≤ 1 ns
Response time t_A (line-earth)	≤ 100 ns
Input attenuation aE, sym.	0.5 dB (≤ 200 kHz)
Cut-off frequency f_g (3 dB), sym. in 50 Ohm system	typ. 1 MHz
Capacity (line-line)	6 nF
Resistance per path	2.2 Ω
Surge protection fault message	none
Impulse durability (line-line)	C2 - 10 kV / 5 kA
Impulse durability (line-earth)	C2 - 10 kV / 5 kA
	D1 - 2.5 kA

Connection data

Connection method	Screw connection (in connection with the base element)
Screw thread	M3
Tightening torque	0.8 Nm
Stripping length	8 mm
Conductor cross section flexible	0.2 mm ² ... 2.5 mm ²
Conductor cross section solid	0.2 mm ² ... 4 mm ²
Conductor cross section AWG	24 ... 12

Standards and Regulations

Standards/regulations	IEC 61643-21
	DIN EN 61643-21
	UL 497B
Standards/specifications	IEC 61643-21 2000

Environmental Product Compliance

REACH SVHC	Lead 7439-92-1
China RoHS	Environmentally Friendly Use Period = 50 years
	For details about hazardous substances go to tab "Downloads", Category "Manufacturer's declaration"

Surge protection plug - PT 2X2- 5DC-ST - 2838241

Drawings

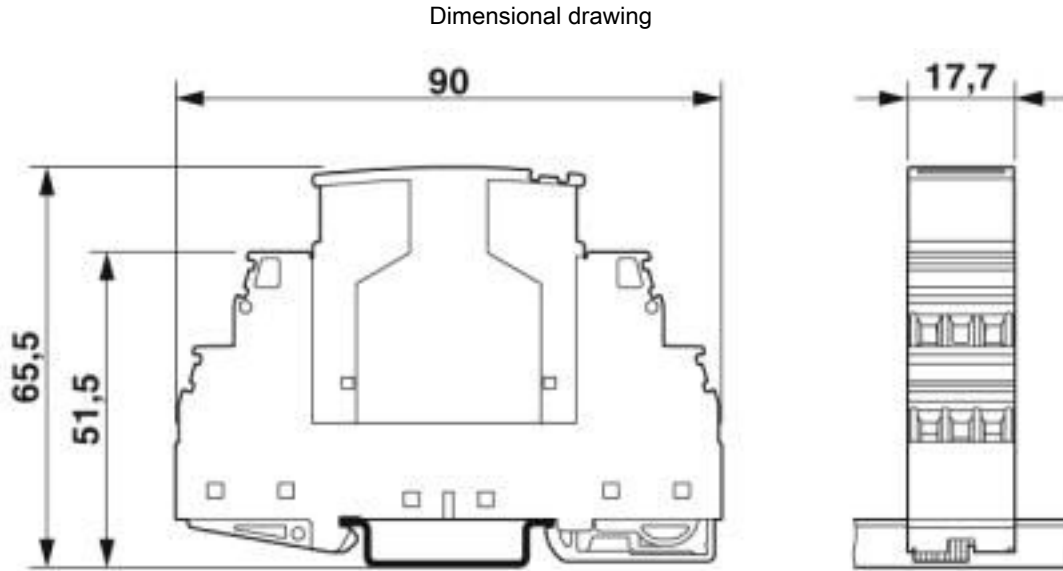

The figure shows the complete module consisting of a base element and connector

Pictogram

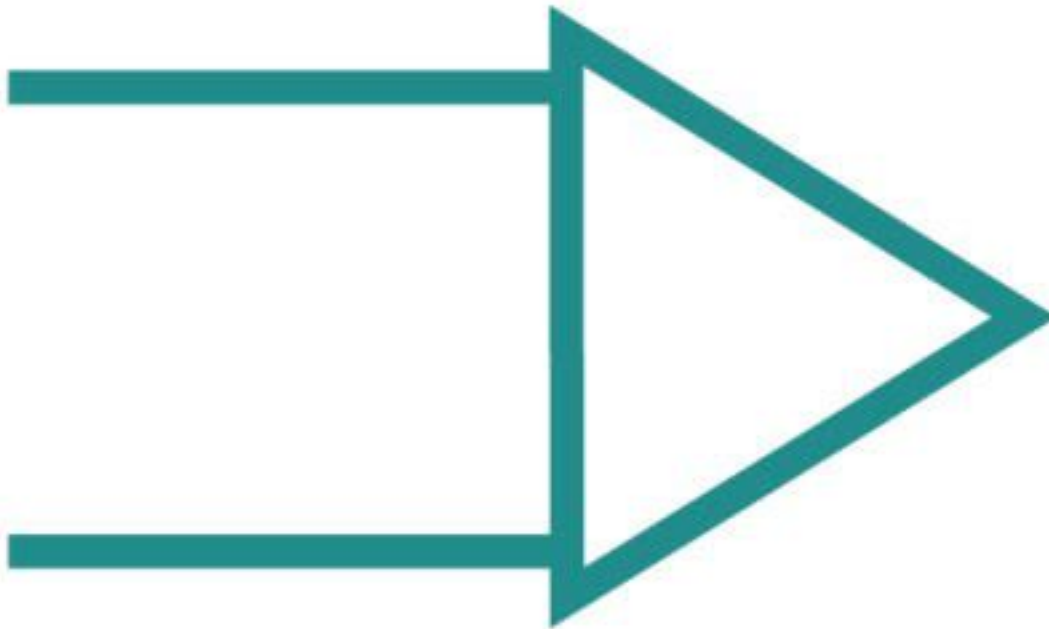

Surge protection plug - PT 2X2- 5DC-ST - 2838241

Circuit diagram

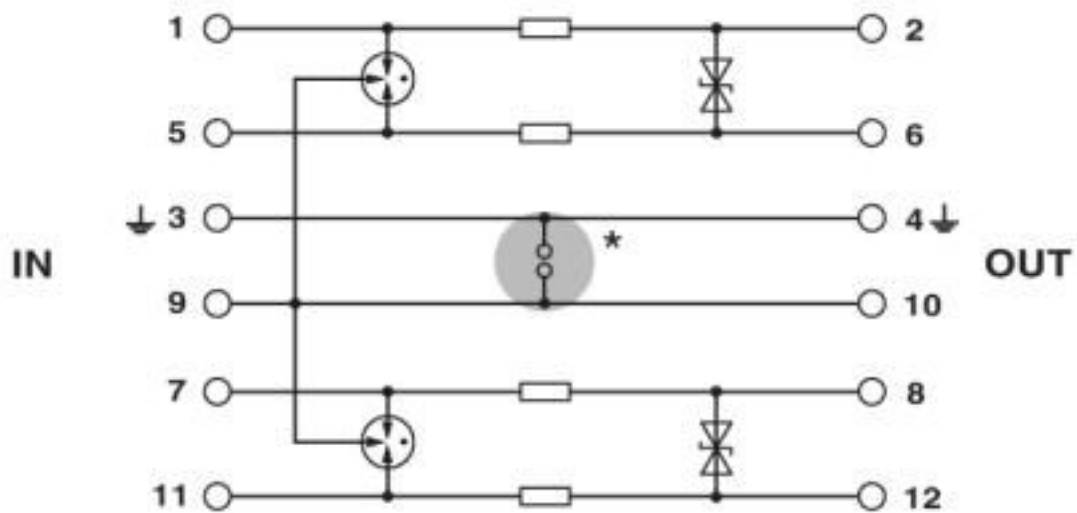

Classifications

eCl@ss

eCl@ss 10.0.1	27130807
eCl@ss 4.0	27130800
eCl@ss 4.1	27130800
eCl@ss 5.0	27130800
eCl@ss 5.1	27130800
eCl@ss 6.0	27130800
eCl@ss 7.0	27130807
eCl@ss 8.0	27130807
eCl@ss 9.0	27130807

ETIM

ETIM 2.0	EC000943
ETIM 3.0	EC000943
ETIM 4.0	EC000943
ETIM 5.0	EC000943
ETIM 6.0	EC000943
ETIM 7.0	EC000943

UNSPSC

UNSPSC 6.01	30212010
UNSPSC 7.0901	39121610
UNSPSC 11	39121610

Surge protection plug - PT 2X2- 5DC-ST - 2838241

Classifications

UNSPSC

UNSPSC 12.01	39121610
UNSPSC 13.2	39121620
UNSPSC 18.0	39121620
UNSPSC 19.0	39121620
UNSPSC 20.0	39121620
UNSPSC 21.0	39121620

Approvals

Approvals

Approvals

UL Listed / EAC / EAC

Ex Approvals

ATEX / UL Listed / cUL Listed / cULus Listed

Approval details

UL Listed		http://database.ul.com/cgi-bin/XYV/template/LISEXT/1FRAME/index.htm	FILE E 138168
Nominal voltage UN		5 V	
Nominal current IN		0.45 A	

EAC		EAC-Zulassung
-----	---	---------------

EAC		RU C- DE.A*30.B01561
-----	---	-------------------------

Accessories

Accessories

Device marking

Surge protection plug - PT 2X2- 5DC-ST - 2838241

Accessories

Zack marker strip - ZBN 18:UNBEDRUCKT - 2809128



Zack marker strip, Strip, white, unlabeled, can be labeled with: CMS-P1-PLOTTER, PLOTMARK, mounting type: snap into tall marker groove, for terminal block width: 18 mm, lettering field size: 18 x 5 mm, Number of individual labels: 5

Labeled terminal marker

Zack Marker strip, flat - ZBF 5,LGS:FORTL.ZAHLEN - 0808671



Zack Marker strip, flat, Strip, white, labeled, printed horizontally: consecutive numbers 1 ... 10, 11 ... 20, etc. up to 491 ... 500, mounting type: snap into flat marker groove, for terminal block width: 5 mm, lettering field size: 5.15 x 5.15 mm, Number of individual labels: 10

Zack Marker strip, flat - ZBF 5,LGS:GERADE ZAHLEN - 0810821



Zack Marker strip, flat, Strip, white, labeled, printed horizontally: consecutive numbers 2 ... 20, 22 ... 40, etc. up to 82 ... 100, mounting type: snap into flat marker groove, for terminal block width: 5 mm, lettering field size: 5.15 x 5.15 mm, Number of individual labels: 10

Zack Marker strip, flat - ZBF 5,LGS:UNGERADE ZAHLEN - 0810863



Zack Marker strip, flat, Strip, white, labeled, printed horizontally: Odd numbers 1 - 19, 21 - 39, etc. up to 81 - 99, mounting type: snap into flat marker groove, for terminal block width: 5 mm, lettering field size: 5.15 x 5.15 mm, Number of individual labels: 10

Zack Marker strip, flat - ZBF 5,QR:FORTL.ZAHLEN - 0808697



Zack Marker strip, flat, Strip, white, labeled, Printed vertically: consecutive numbers 1 ... 10, 11 ... 20, etc. up to 91 ... 100, mounting type: snap into flat marker groove, for terminal block width: 5 mm, lettering field size: 5.15 x 5.15 mm, Number of individual labels: 10

Surge protection plug - PT 2X2- 5DC-ST - 2838241

Accessories

Marker pen

Marker pen - X-PEN 0,35 - 0811228



Marker pen without ink cartridge, for manual labeling of markers, labeling extremely wipe-proof, line thickness 0.35 mm

Terminal marking

Zack Marker strip, flat - ZBF 5:UNBEDRUCKT - 0808642



Zack Marker strip, flat, Strip, white, unlabeled, can be labeled with: PLOTMARK, CMS-P1-PLOTTER, mounting type: snap into flat marker groove, for terminal block width: 5 mm, lettering field size: 5.1 x 5.2 mm, Number of individual labels: 10

Zack Marker strip, flat - ZBF 5/WH-100:UNBEDRUCKT - 0808668



Zack Marker strip, flat, Strip, white, unlabeled, can be labeled with: CMS-P1-PLOTTER, PLOTMARK, mounting type: snap into flat marker groove, for terminal block width: 5 mm, lettering field size: 5.15 x 5.15 mm, Number of individual labels: 10

Necessary add-on products

Surge protection base element - PT 2X2-BE - 2839208



Base element for protective plug PT with protective circuit for two 2-wire floating signal circuit, bridge between the connections 3-4 (GND) and 9-10, for mounting on NS 35/7.5 and NS 35/15, housing width: 17.5 mm

Surge protection plug - PT 2X2- 5DC-ST - 2838241

Accessories

Surge protection base element - PT 2X2+F-BE - 2839224



Base element for protective plug PT with protective circuit for two 2-wire floating signal circuit, gas-filled surge arrester between the connections 3-4 (GND) and 9-10, for mounting on NS 35/7.5 and NS 35/15, housing width: 17.5 mm

Additional products

Shield connection - SSA 3-6 - 2839295



Shield fast connection for 3 ... 6 mm cable diameter. Potential connecting cable: 200 mm, 1 mm², color: black

Shield connection - SSA 5-10 - 2839512



Shield fast connection for 5 ... 10 mm cable diameter. Potential connecting cable: 200 mm, 1 mm², color: black