

Device terminal block - G 5/ 4 - 2716046

Please be informed that the data shown in this PDF Document is generated from our Online Catalog. Please find the complete data in the user's documentation. Our General Terms of Use for Downloads are valid (<http://phoenixcontact.com/download>)



Device terminal block, for direct mounting, 4-pos.

The figure shows a combination of versions G 5/2, G 5/3 and G 5/4

Your advantages

- Touch-proof shock protection



Key Commercial Data

Packing unit	1 pc
GTIN	 4 017918 061784
GTIN	4017918061784
Weight per Piece (excluding packing)	28.900 g
Custom tariff number	85369010
Country of origin	Turkey

Technical data

General

Number of positions	4
Number of levels	1
Number of connections	8
Potentials	4
Nominal cross section	4 mm ²
Color	gray
Insulating material	PA

Device terminal block - G 5/ 4 - 2716046

Technical data

General

Flammability rating according to UL 94	V0
Rated surge voltage	6 kV
Degree of pollution	3
Overvoltage category	III
Insulating material group	I
Maximum power dissipation for nominal condition	1.02 W
Maximum load current	32 A (with 4 mm ² conductor cross section)
Nominal current I _N	32 A
Nominal voltage U _N	500 V
Open side panel	No
Terminal block mounting	When attaching the product to the mounting surface, please ensure that the housing is not damaged when tightening the center screw
Ambient temperature (operation)	-60 °C ... 85 °C
Ambient temperature (storage/transport)	-25 °C ... 55 °C (For a short time, not exceeding 24 h, -60 to +70 °C)
Permissible humidity (storage/transport)	30 % ... 70 %
Ambient temperature (assembly)	-5 °C ... 70 °C
Ambient temperature (actuation)	-5 °C ... 70 °C
Shock protection test specification	IEC 60529:2001-02
Back of the hand protection	guaranteed
Finger protection	guaranteed
Result of surge voltage test	Test passed
Result of power-frequency withstand voltage test	Test passed
Power frequency withstand voltage setpoint	1.89 kV
Result of the test for mechanical stability of terminal points (5 x conductor connection)	Test passed
Result of bending test	Test passed
Bending test rotation speed	10 rpm
Bending test turns	135
Bending test conductor cross section/weight	0.2 mm ² / 0.2 kg
	1.5 mm ² / 0.4 kg
	4 mm ² / 0.9 kg
Tensile test result	Test passed
Result of voltage-drop test	Test passed
Result of temperature-rise test	Test passed
Requirement temperature-rise test	Increase in temperature ≤ 45 K
Short circuit stability result	Test passed
Conductor cross section short circuit testing	4 mm ²
Short-time current	0.48 kA

Device terminal block - G 5/ 4 - 2716046

Technical data

General

Result of thermal test	Test passed
Proof of thermal characteristics (needle flame) effective duration	30 s
Relative insulation material temperature index (Elec., UL 746 B)	130 °C
Temperature index of insulation material (DIN EN 60216-1 (VDE 0304-21))	130 °C
Static insulating material application in cold	-60 °C
Surface flammability NFPA 130 (ASTM E 162)	passed
Specific optical density of smoke NFPA 130 (ASTM E 662)	passed
Calorimetric heat release NFPA 130 (ASTM E 1354)	28 MJ/kg
Smoke gas toxicity NFPA 130 (SMP 800C)	passed
Fire protection for rail vehicles (DIN EN 45545-2) R22	HL 1 - HL 3
Fire protection for rail vehicles (DIN EN 45545-2) R23	HL 1 - HL 3
Fire protection for rail vehicles (DIN EN 45545-2) R24	HL 1 - HL 3
Fire protection for rail vehicles (DIN EN 45545-2) R26	HL 1 - HL 3

Dimensions

Width	38 mm
Length	22 mm
Height	24 mm

Connection data

Connection method	Screw connection
Screw thread	M3
Stripping length	8 mm
Tightening torque, min	0.6 Nm
Tightening torque max	0.8 Nm
Connection in acc. with standard	IEC 60947-7-1/IEC 60998
Conductor cross section solid min.	0.2 mm ²
Conductor cross section solid max.	4 mm ²
Conductor cross section AWG min.	24
Conductor cross section AWG max.	12
Conductor cross section flexible min.	0.2 mm ²
Conductor cross section flexible max.	4 mm ²
Min. AWG conductor cross section, flexible	24
Max. AWG conductor cross section, flexible	12
Conductor cross section flexible, with ferrule without plastic sleeve min.	0.25 mm ²
Conductor cross section flexible, with ferrule without plastic sleeve max.	4 mm ²
Conductor cross section flexible, with ferrule with plastic sleeve min.	0.25 mm ²
Conductor cross section flexible, with ferrule with plastic sleeve max.	2.5 mm ²

Device terminal block - G 5/ 4 - 2716046

Technical data

Connection data

2 conductors with same cross section, solid min.	0.2 mm ²
2 conductors with same cross section, solid max.	1.5 mm ²
2 conductors with same cross section, stranded min.	0.2 mm ²
2 conductors with same cross section, stranded max.	1.5 mm ²
Two conductors with the same cross section, flexible, with TWIN ferrules, with plastic sleeve, minimum	0.5 mm ²
Two conductors with the same cross section, flexible, with TWIN ferrules, with plastic sleeve, maximum	1 mm ²
Two conductors with the same cross section stranded, with ferrule and without plastic sleeve, minimum	0.25 mm ²
Two conductors with the same cross section stranded, with ferrule and without plastic sleeve, maximum	1.5 mm ²
Internal cylindrical gage	A3

Standards and Regulations

Connection in acc. with standard	CSA
	IEC 60947-7-1/IEC 60998
Flammability rating according to UL 94	V0

Environmental Product Compliance

REACH SVHC	Lead 7439-92-1
China RoHS	Environmentally Friendly Use Period = 50 years
	For details about hazardous substances go to tab "Downloads", Category "Manufacturer's declaration"

Drawings

Dimensional drawing

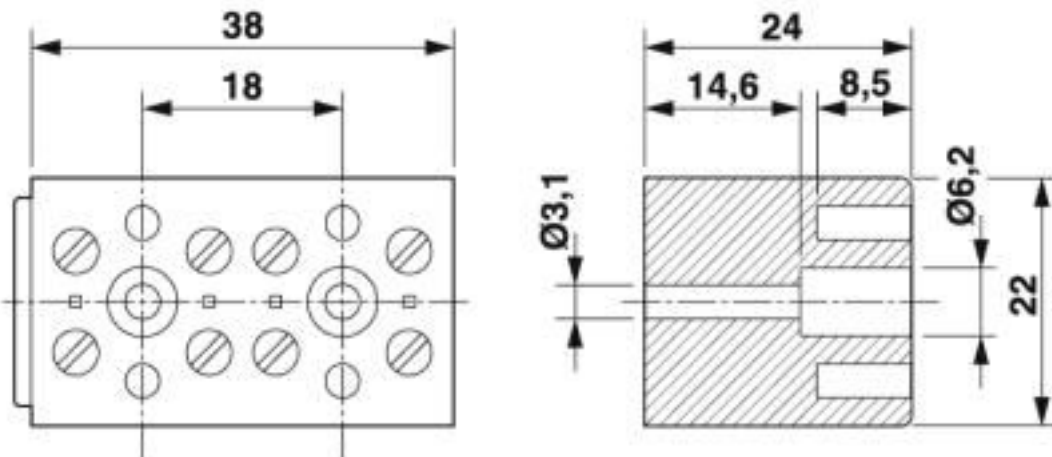

Device terminal block - G 5/ 4 - 2716046

Circuit diagram

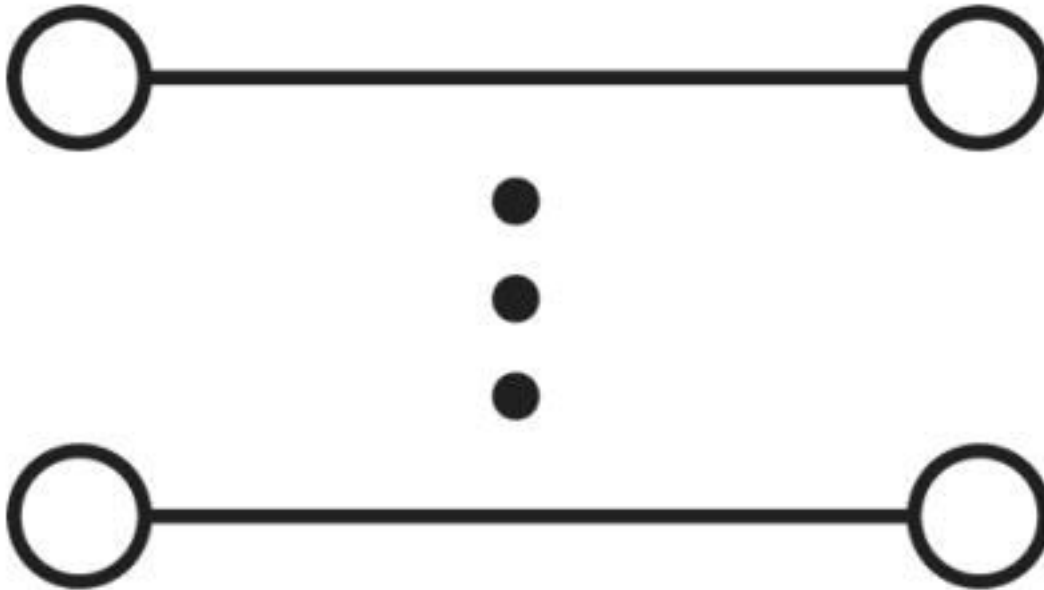

Classifications

eCl@ss

eCl@ss 10.0.1	27141120
eCl@ss 4.0	27141100
eCl@ss 4.1	27141100
eCl@ss 5.0	27141100
eCl@ss 5.1	27141100
eCl@ss 6.0	27141100
eCl@ss 7.0	27141106
eCl@ss 8.0	27141106
eCl@ss 9.0	27141120

ETIM

ETIM 2.0	EC001284
ETIM 3.0	EC001284
ETIM 4.0	EC001284
ETIM 5.0	EC001284
ETIM 6.0	EC001284
ETIM 7.0	EC001284

Device terminal block - G 5/ 4 - 2716046

Classifications

UNSPSC

UNSPSC 6.01	30211811
UNSPSC 7.0901	39121410
UNSPSC 11	39121410
UNSPSC 12.01	39121410
UNSPSC 13.2	39121409
UNSPSC 18.0	39121410
UNSPSC 19.0	39121410
UNSPSC 20.0	39121410
UNSPSC 21.0	39121410

Approvals

Approvals

Approvals

CSA / NK / UL Recognized / cUL Recognized / EAC / RS / cULus Recognized

Ex Approvals

Approval details

CSA		http://www.csagroup.org/services-industries/product-listing/	13631
Nominal voltage UN		300 V	
Nominal current IN		30 A	
mm ² /AWG/kcmil		26-10	

NK		http://www.classnk.or.jp/hp/en/	09 ME 142
----	--	---	-----------

Device terminal block - G 5/ 4 - 2716046

Approvals

UL Recognized		http://database.ul.com/cgi-bin/XYV/template/LISEXT/1FRAME/index.htm	FILE E 60425
Nominal voltage UN		300 V	
Nominal current IN		30 A	
mm ² /AWG/kcmil		26-10	

cUL Recognized		http://database.ul.com/cgi-bin/XYV/template/LISEXT/1FRAME/index.htm	FILE E 60425
Nominal voltage UN		300 V	
Nominal current IN		30 A	
mm ² /AWG/kcmil		26-10	

EAC		RU C- DE.BL08.B.00534
-----	--	--------------------------

RS		http://www.rs-head.spb.ru/en/index.php	17.00013.272
----	--	---	--------------

cULus Recognized	
------------------	--

Accessories

Accessories

Labeled terminal marker

Warning label - WS-G5/4 - 2716499

Warning plate, for the device terminal block G 5, completely covers the surface of the terminal block, 4-pos.



Device terminal block - G 5/ 4 - 2716046

Accessories

Screwdriver tools

Screwdriver - SZS 0,6X3,5 - 1205053



Actuation tool, for ST terminal blocks, insulated, also suitable for use as a bladed screwdriver, size: 0.6 x 3.5 x 100 mm, 2-component grip, with non-slip grip

Terminal marking

Marker for terminal blocks - BN WH - 1401404



Marker for terminal blocks, Stud, white, unlabeled, can be labeled with: Marker pen, mounting type: plug in, for terminal block width: 4.2 mm, lettering field size: 4 x 4 mm
