

## Power supply unit - QUINT-PS/2AC/1DC/24DC/20 - 2320830

Please be informed that the data shown in this PDF Document is generated from our Online Catalog. Please find the complete data in the user's documentation. Our General Terms of Use for Downloads are valid (<http://phoenixcontact.com/download>)



Primary-switched DIN rail power supply unit. AC input: suitable for operation between two phases (400 V AC). DC input: suitable for operation in an FI intermediate circuit. Output: 24 V DC/20 A.

### Product Description

QUINT POWER power supply units – Superior system availability with SFB technology

Compact power supply units of the new QUINT POWER generation maximize the availability of your system. With the SFB technology (Selective Fuse Breaking Technology), six times the nominal current for 12 ms, even the standard power circuit-breakers can now also be triggered reliably and quickly. Faulty current paths are switched off selectively, the fault is located and important system parts continue to operate. Comprehensive diagnostics are provided through constant monitoring of output voltage and current. This preventive function monitoring visualizes critical operating modes and reports them to the control unit before an error can occur.

### Your advantages

- ✓ Compact buffer solution
- ✓ Fast tripping of standard circuit breakers
- ✓ Preventive function monitoring
- ✓ Reliable starting of difficult loads and easy system extension



### Key Commercial Data

Packing unit	1 pc
GTIN	 4 046356 580915
GTIN	4046356580915
Weight per Piece (excluding packing)	2,100.000 g
Custom tariff number	85044030
Country of origin	China

### Technical data

#### Note

# Power supply unit - QUINT-PS/2AC/1DC/24DC/20 - 2320830

## Technical data

### Note

Utilization restriction	EMC: class A product, see manufacturer's declaration in the download area
-------------------------	---

### Dimensions

Width	120 mm
Height	130 mm
Depth	125 mm
Installation distance right/left	5 mm / 5 mm
Installation distance top/bottom	50 mm / 50 mm

### Ambient conditions

Degree of protection	IP20
Ambient temperature (operation)	-25 °C ... 70 °C (> 60 °C Derating: 2.5 %/K)
Ambient temperature (storage/transport)	-40 °C ... 85 °C
Max. permissible relative humidity (operation)	≤ 95 % (at 25 °C, non-condensing)
Climatic class	3K3 (in acc. with EN 60721)
Degree of pollution	2
Installation height	≤ 2000 m

### Input data

Nominal input voltage range	2x 400 V AC ... 500 V AC
	600 V DC
Input voltage range	2x 360 V AC ... 575 V AC
	450 V DC ... 840 V DC
AC frequency range	45 Hz ... 65 Hz
Frequency range DC	0 Hz
Current consumption	2.5 A (400 V AC)
	2.1 A (500 V AC)
Nominal power consumption	888 VA
Inrush current	< 85 A (typical)
Mains buffering time	typ. 20 ms (400 V AC)
Input fuse	3.15 A (slow-blow, internal)
Recommended breaker for input protection	10 A ... 16 A (Characteristic B, C)
Type of protection	Transient surge protection
Protective circuit/component	Varistor

### Output data

Nominal output voltage	24 V DC ±1 %
Setting range of the output voltage ( $U_{Set}$ )	18 V DC ... 29.5 V DC ( $U_{IN} \geq 360$ V AC / 480 V DC)
	18 V DC ... 26 V DC (< 480 V DC)

## Power supply unit - QUINT-PS/2AC/1DC/24DC/20 - 2320830

### Technical data

#### Output data

Nominal output current ( $I_N$ )	20 A (-25 °C ... 60 °C)
POWER BOOST ( $I_{Boost}$ )	26 A (-25°C ... 40°C permanent, $U_{OUT} = 24$ V DC )
Selective Fuse Breaking ( $I_{SFB}$ )	120 A (20 ms)
Derating	60 °C ... 70 °C (2.5%/K)
Connection in parallel	Yes, for redundancy and increased capacity
Connection in series	yes
Feedback voltage resistance	< 35 V DC
Protection against overvoltage at the output (OVP)	< 35 V DC
Max. capacitive load	unlimited
Active current limitation	Approx. 27 A
Control deviation	< 1 % (change in load, static 10 % ... 90 %)
	< 2 % (change in load, dynamic 10 % ... 90 %)
	< 0.1 % (change in input voltage $\pm 10$ %)
Residual ripple	< 50 mV <sub>PP</sub> (with nominal values)
Output power	480 W
Peak switching voltages nominal load	< 50 mV <sub>PP</sub> (20 MHz)
Maximum power dissipation in no-load condition	11 W
Power loss nominal load max.	51 W

#### General

Net weight	2 kg
Efficiency	> 92 % (600 V DC)
	> 90.5 % (400 V AC)
	> 860000 h (40 °C)
Insulation voltage input/output	1.5 kV AC (type test)
	2 kV AC (routine test)
Insulation voltage input / PE	4 kV AC (type test)
	1.5 kV AC (routine test)
Insulation voltage output / PE	500 V DC (routine test)
Degree of protection	IP20
Protection class	I
Housing material	Steel sheet, zinc-plated
Mounting position	horizontal DIN rail NS 35, EN 60715
Assembly instructions	alignable: $P_N \geq 50\%$ , 5 mm horizontally, 15 mm next to active components, 50 mm vertically alignable: $P_N < 50\%$ , 0 mm horizontally, 40 mm vertically top, 20 mm vertically bottom

#### Connection data, input

## Power supply unit - QUINT-PS/2AC/1DC/24DC/20 - 2320830

### Technical data

#### Connection data, input

Connection method	Screw connection
Conductor cross section solid min.	0.2 mm <sup>2</sup>
Conductor cross section solid max.	6 mm <sup>2</sup>
Conductor cross section flexible min.	0.2 mm <sup>2</sup>
Conductor cross section flexible max.	4 mm <sup>2</sup>
Conductor cross section AWG min.	24
Conductor cross section AWG max.	10
Stripping length	8 mm
Screw thread	M3

#### Connection data, output

Connection method	Screw connection
Conductor cross section solid min.	0.2 mm <sup>2</sup>
Conductor cross section solid max.	6 mm <sup>2</sup>
Conductor cross section flexible min.	0.2 mm <sup>2</sup>
Conductor cross section flexible max.	4 mm <sup>2</sup>
Conductor cross section AWG min.	12
Conductor cross section AWG max.	10
Stripping length	8 mm
Screw thread	M3

#### Connection data for signaling

Conductor cross section solid min.	0.2 mm <sup>2</sup>
Conductor cross section solid max.	6 mm <sup>2</sup>
Conductor cross section flexible min.	0.2 mm <sup>2</sup>
Conductor cross section flexible max.	4 mm <sup>2</sup>
Conductor cross section AWG min.	24
Conductor cross section AWG max.	10
Screw thread	M3

#### Standards

Standard - Safety of transformers	EN 61558-2-17
Standard - Electrical safety	EN 60950-1/VDE 0805 (SELV)
Standard – Electronic equipment for use in electrical power installations and their assembly into electrical power installations	EN 50178/VDE 0160 (PELV)
Standard - Safe isolation	DIN VDE 0100-410
Rail applications	EN 50121-4

#### Conformance/approvals

UL approvals	UL/C-UL listed UL 508
--------------	-----------------------

# Power supply unit - QUINT-PS/2AC/1DC/24DC/20 - 2320830

## Technical data

### Conformance/approvals

	UL/C-UL Recognized UL 60950-1
--	-------------------------------

### EMC data

Electromagnetic compatibility	Conformance with EMC Directive 2014/30/EU
-------------------------------	---

### Environmental Product Compliance

REACH SVHC	Lead 7439-92-1
------------	----------------

## Drawings

Block diagram

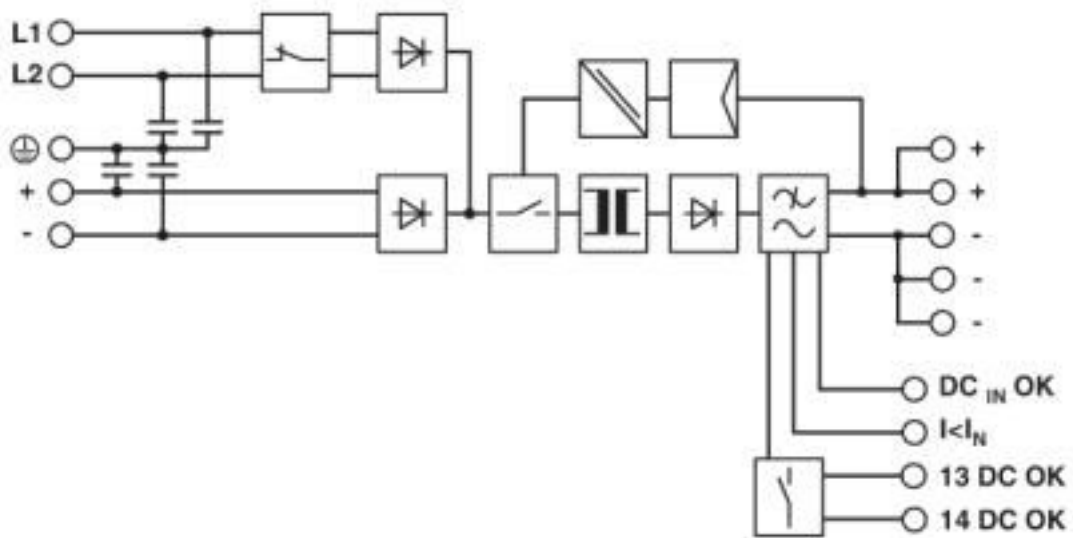

## Classifications

### eCl@ss

eCl@ss 10.0.1	27040701
eCl@ss 4.0	27040700
eCl@ss 4.1	27040700
eCl@ss 5.0	27049000
eCl@ss 5.1	27049000
eCl@ss 6.0	27049000
eCl@ss 7.0	27049002
eCl@ss 8.0	27049002
eCl@ss 9.0	27040701

# Power supply unit - QUINT-PS/2AC/1DC/24DC/20 - 2320830

## Classifications

### ETIM

ETIM 3.0	EC001039
ETIM 4.0	EC002540
ETIM 5.0	EC002540
ETIM 6.0	EC002540
ETIM 7.0	EC002540

### UNSPSC

UNSPSC 6.01	30211502
UNSPSC 7.0901	39121004
UNSPSC 11	39121004
UNSPSC 12.01	39121004
UNSPSC 13.2	39121004
UNSPSC 18.0	39121004
UNSPSC 19.0	39121004
UNSPSC 20.0	39121004
UNSPSC 21.0	39121004

## Approvals

### Approvals

#### Approvals

UL Listed / UL Recognized / cUL Recognized / cUL Listed / UL Recognized / UL Listed / cUL Listed / cUL Recognized / EAC / EAC

#### Ex Approvals

### Approval details

UL Listed		<a href="http://database.ul.com/cgi-bin/XYV/template/LISEXT/1FRAME/index.htm">http://database.ul.com/cgi-bin/XYV/template/LISEXT/1FRAME/index.htm</a>	FILE E 123528
-----------	--	---	---------------

UL Recognized		<a href="http://database.ul.com/cgi-bin/XYV/template/LISEXT/1FRAME/index.htm">http://database.ul.com/cgi-bin/XYV/template/LISEXT/1FRAME/index.htm</a>	FILE E 211944
---------------	--	---	---------------

# Power supply unit - QUINT-PS/2AC/1DC/24DC/20 - 2320830

## Approvals

cUL Recognized		<a href="http://database.ul.com/cgi-bin/XYV/template/LISEXT/1FRAME/index.htm">http://database.ul.com/cgi-bin/XYV/template/LISEXT/1FRAME/index.htm</a>	FILE E 211944
cUL Listed		<a href="http://database.ul.com/cgi-bin/XYV/template/LISEXT/1FRAME/index.htm">http://database.ul.com/cgi-bin/XYV/template/LISEXT/1FRAME/index.htm</a>	FILE E 123528
UL Recognized		<a href="http://database.ul.com/cgi-bin/XYV/template/LISEXT/1FRAME/index.htm">http://database.ul.com/cgi-bin/XYV/template/LISEXT/1FRAME/index.htm</a>	FILE E 211944
UL Listed		<a href="http://database.ul.com/cgi-bin/XYV/template/LISEXT/1FRAME/index.htm">http://database.ul.com/cgi-bin/XYV/template/LISEXT/1FRAME/index.htm</a>	FILE E 123528
cUL Listed		<a href="http://database.ul.com/cgi-bin/XYV/template/LISEXT/1FRAME/index.htm">http://database.ul.com/cgi-bin/XYV/template/LISEXT/1FRAME/index.htm</a>	FILE E 123528
cUL Recognized		<a href="http://database.ul.com/cgi-bin/XYV/template/LISEXT/1FRAME/index.htm">http://database.ul.com/cgi-bin/XYV/template/LISEXT/1FRAME/index.htm</a>	FILE E 211944
EAC			EAC-Zulassung
EAC			EAC-Zulassung

## Accessories

Accessories

Device protection

## Power supply unit - QUINT-PS/2AC/1DC/24DC/20 - 2320830

### Accessories

Type 3 surge protection device - PLT-SEC-T3-24-FM-UT - 2907916



Type 3 surge protection, consisting of protective plug and base element, with integrated status indicator and remote signaling for single-phase power supply networks. Nominal voltage 24 V AC/DC.