

## Contact insert - VC-TFS 8 - 1852820

Please be informed that the data shown in this PDF Document is generated from our Online Catalog. Please find the complete data in the user's documentation. Our General Terms of Use for Downloads are valid (<http://phoenixcontact.com/download>)



Contact insert module, for sleeve frames, with screw connection, 8-pos., 160 V / 10 A

### Your advantages

- Compact design
- Proven COMBICON technology
- Universal connection
- Can be keyed to prevent incorrect connection

### Key Commercial Data

Packing unit	1 pc
Minimum order quantity	50 pc
GTIN	
GTIN	4017918127152
Weight per Piece (excluding packing)	7.250 g
Custom tariff number	85366990
Country of origin	Poland

### Technical data

#### General

Note	Connectors may only be connected/disconnected when under no load.
Connection technology	Screw connection
Connection method	Screw connection
Tightening torque	0.22 Nm ... 0.25 Nm
Degree of pollution	3

# Contact insert - VC-TFS 8 - 1852820

## Technical data

### General

Number of positions	8
Insertion/withdrawal cycles	≥ 100
Conductor cross section	0.14 mm <sup>2</sup> ... 1.5 mm <sup>2</sup>
Connection cross section AWG	28 ... 16
Stripping length of the individual wire	6 mm

### Ambient conditions

Ambient temperature (operation)	-40 °C ... 100 °C
---------------------------------	-------------------

### Material data

Contact material	CuZn
Contact surface material	Tin-plated
Contact carrier material	PA

### Electrical characteristics

Rated voltage (III/3)	160 V
Rated surge voltage	2.5 kV
	2.5 kV
Rated current	10 A
	10 A

### Standards and Regulations

Connection in acc. with standard	CUL
Flammability rating according to UL 94	V0
Safety note	WARNING: The connectors may not be plugged in or disconnected under load. Ignoring the warning or improper use may damage persons and/or property.
	<ul style="list-style-type: none"> <li>• WARNING: Commission properly functioning products only. The products must be regularly inspected for damage. Decommission defective products immediately. Replace damaged products. Repairs are not possible.</li> </ul>
	<ul style="list-style-type: none"> <li>• WARNING: Only electrically qualified personnel may install and operate the product. They must observe the following safety notes. The qualified personnel must be familiar with the basics of electrical engineering. They must be able to recognize and prevent danger. The relevant symbol on the packaging indicates that only personnel familiar with electrical engineering are allowed to install and operate the product.</li> </ul>
	<ul style="list-style-type: none"> <li>• The products are suitable for applications in plant, controller, and electrical device engineering.</li> </ul>
	<ul style="list-style-type: none"> <li>• When operating the connectors in outdoor applications, they must be separately protected against environmental influences.</li> </ul>
	<ul style="list-style-type: none"> <li>• Assembled products may not be manipulated or improperly opened.</li> </ul>
	<ul style="list-style-type: none"> <li>• Only use mating connectors that are specified in the technical data of the standards listed (e.g. the ones listed in the product accessories online at <a href="https://www.phoenixcontact.com/products">phoenixcontact.com/products</a>).</li> </ul>

## Contact insert - VC-TFS 8 - 1852820

### Technical data

#### Standards and Regulations

	<ul style="list-style-type: none"> <li>When using the product in direct connection with third-party manufacturers, the user is responsible.</li> </ul>
	<ul style="list-style-type: none"> <li>For operating voltages &gt; 50 V AC, conductive connector housings must be grounded</li> </ul>
	<ul style="list-style-type: none"> <li>Ensure that the protective or functional ground has been properly connected.</li> </ul>
	<ul style="list-style-type: none"> <li>VDE 0100/1.97 § 411.1.3.2 and DIN EN 60 204/11.98 § 14.1.3 are applicable when combining several circuits in a cable and/or connector</li> </ul>
	<ul style="list-style-type: none"> <li>Observe the corresponding technical data. You will find information:                             <ul style="list-style-type: none"> <li>On the product</li> <li>On the packing label</li> <li>In the supplied documentation</li> <li>Online at <a href="https://www.phoenixcontact.com/products">phoenixcontact.com/products</a> under the product</li> </ul> </li> </ul>
	<ul style="list-style-type: none"> <li>Only use tools recommended by Phoenix Contact</li> </ul>
	<ul style="list-style-type: none"> <li>The installation notes/Design In documents online on the download page at <a href="https://www.phoenixcontact.com/products">phoenixcontact.com/products</a> must be observed for this product.</li> </ul>
	<ul style="list-style-type: none"> <li>Use a protective cap to protect connectors that are not in use. The suitable accessories are available online in the accessory section of the product at <a href="https://www.phoenixcontact.com/products">phoenixcontact.com/products</a></li> </ul>
	<ul style="list-style-type: none"> <li>Operate the connector only when it is fully plugged in.</li> </ul>
	<ul style="list-style-type: none"> <li>Ensure that when laying the cable, the tensile load on the connectors does not exceed the upper limit specified in the standards.</li> </ul>
	<ul style="list-style-type: none"> <li>Observe the minimum bending radius of the cable. Lay the cable without twisting it.</li> </ul>

#### Environmental Product Compliance

REACH SVHC	Lead 7439-92-1
China RoHS	Environmentally Friendly Use Period = 50 years
	For details about hazardous substances go to tab "Downloads", Category "Manufacturer's declaration"

### Drawings

# Contact insert - VC-TFS 8 - 1852820

Dimensional drawing

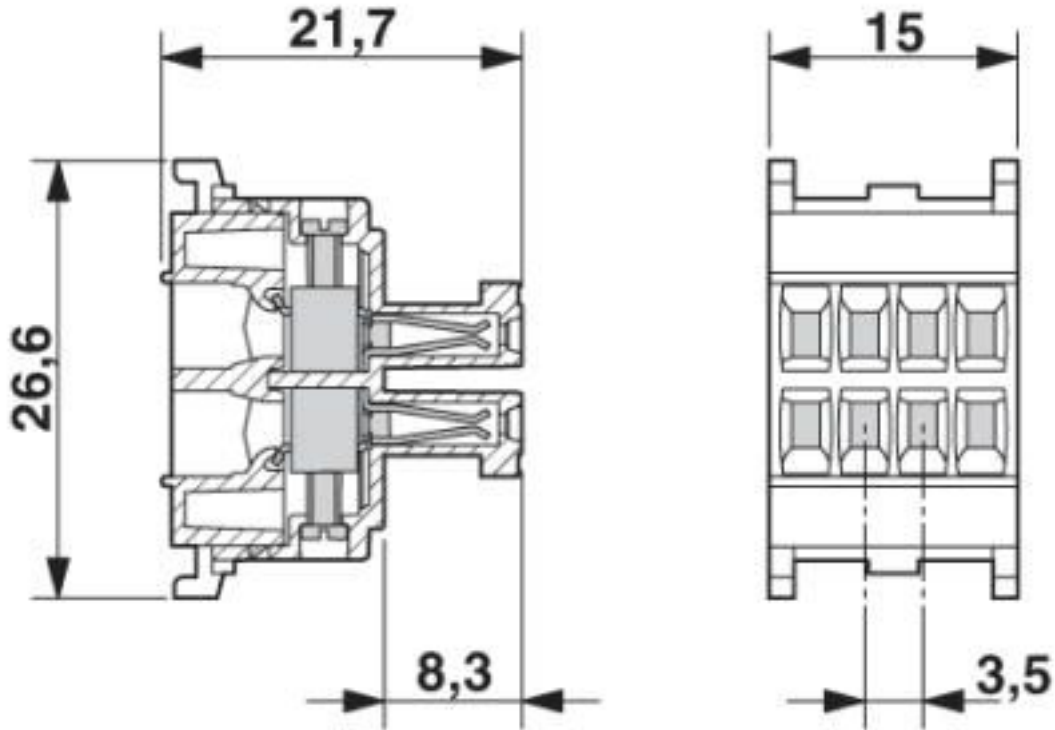

## Classifications

### eCl@ss

eCl@ss 10.0.1	27440205
eCl@ss 4.0	27140800
eCl@ss 4.1	27140800
eCl@ss 5.0	27371200
eCl@ss 5.1	27261200
eCl@ss 6.0	27261200
eCl@ss 7.0	27440205
eCl@ss 8.0	27440205
eCl@ss 9.0	27440205

### ETIM

ETIM 2.0	EC000437
ETIM 3.0	EC000437
ETIM 4.0	EC000437
ETIM 5.0	EC000438

# Contact insert - VC-TFS 8 - 1852820

## Classifications

### ETIM

ETIM 6.0	EC000438
ETIM 7.0	EC000438

### UNSPSC

UNSPSC 6.01	31261501
UNSPSC 7.0901	31261501
UNSPSC 11	31261501
UNSPSC 12.01	31261501
UNSPSC 13.2	39121522
UNSPSC 18.0	39121522
UNSPSC 19.0	39121522
UNSPSC 20.0	39121522
UNSPSC 21.0	39121522

## Approvals

### Approvals

#### Approvals

UL Recognized / cUL Recognized / EAC / cULus Recognized

#### Ex Approvals

### Approval details

UL Recognized		<a href="http://database.ul.com/cgi-bin/XYV/template/LISEXT/1FRAME/index.htm">http://database.ul.com/cgi-bin/XYV/template/LISEXT/1FRAME/index.htm</a>	FILE E 118976
Nominal voltage UN	250 V		
Nominal current IN	8 A		
mm <sup>2</sup> /AWG/kcmil	30-14		

# Contact insert - VC-TFS 8 - 1852820

## Approvals

cUL Recognized		<a href="http://database.ul.com/cgi-bin/XYV/template/LISEXT/1FRAME/index.htm">http://database.ul.com/cgi-bin/XYV/template/LISEXT/1FRAME/index.htm</a>	FILE E 118976
Nominal voltage UN		250 V	
Nominal current IN		8 A	
mm <sup>2</sup> /AWG/kcmil		30-14	

EAC		B.01742
-----	--	---------

cULus Recognized	
------------------	--

## Accessories

### Accessories

#### Coding element

Coding profile - CP-MSTB - 1734634

Coding profile, is inserted into the slot on the plug or inverted header, red insulating material



Coding profile - CP-HCC 4 - 1600027

Coding profile, number of positions: 1, pitch: 0 mm, color: red



#### Labeled terminal marker

## Contact insert - VC-TFS 8 - 1852820

### Accessories

Marker card - SK 7,5/3,8:FORTL.ZAHLEN - 0804455



Marker card, Card, white, labeled, horizontal: consecutive numbers 1 ... 10, 11 ... 20, etc. up to 91 ... 100, mounting type: adhesive, for terminal block width: 7.5 mm, lettering field size: 7.5 x 3.8 mm

Marker card - SK 5/3,8:FORTL.ZAHLEN - 0804183



Marker card, Card, white, labeled, horizontal: consecutive numbers 1 ... 10, 11 ... 20, etc. up to 91 ... (99)100, mounting type: adhesive, for terminal block width: 5 mm, lettering field size: 5 x 3.8 mm

Marker card - SK 3,5/2,8:FORTL.ZAHLEN - 0804073



Marker card, Card, white, labeled, horizontal: consecutive numbers 1 ... 10, 11 ... 20, etc. up to 91 ... 99, mounting type: adhesive, for terminal block width: 3.5 mm, lettering field size: 3.5 x 2.8 mm

### Terminal marking

Marker card - SK U/5,0 WH:UNBEDRUCKT - 0803922



Marker card, Sheet, white, unlabeled, can be labeled with: PLOTMARK, CMS-P1-PLOTTER, Office printing systems, mounting type: adhesive, for terminal block width: 210 mm, lettering field size: 186 x 5 mm, Number of individual labels: 630

Marker card - SK U/3,8 WH:UNBEDRUCKT - 0803906



Marker card, Sheet, white, unlabeled, can be labeled with: PLOTMARK, CMS-P1-PLOTTER, Office printing systems, mounting type: adhesive, for terminal block width: 210 mm, lettering field size: 186 x 3.8 mm, Number of individual labels: 1440

