

Protective covers - HC-B 16-SD-FQ/FS - 1772599

Please be informed that the data shown in this PDF Document is generated from our Online Catalog. Please find the complete data in the user's documentation. Our General Terms of Use for Downloads are valid (<http://phoenixcontact.com/download>)



Protective cover B16, for double locking latch, protective cover material: PA, height: 18 mm, seal: no, With lanyard, diameter of retaining cord eyelet: 30 mm



COMPLETE

Key Commercial Data

Packing unit	1 pc
Minimum order quantity	10 pc
GTIN	 4 017918 037260
GTIN	4017918037260
Weight per Piece (excluding packing)	34.120 g
Custom tariff number	85389099
Country of origin	Germany

Technical data

Dimensions

Length	96 mm
Width	43 mm
Height	18 mm
Diameter of retaining cord eyelet	30 mm

Ambient conditions

Degree of protection (IP)	IP66
Ambient temperature (operation)	-20 °C ... 100 °C

General

Size	B16
------	-----

Protective covers - HC-B 16-SD-FQ/FS - 1772599

Technical data

General

Type	For supporting base element with double locking latch
Material	PA
Flammability rating according to UL 94	HB
Color	gray
Seal present	no
Assembly instructions	Not for HC-B...EMC housings
Connection	Plastic protective cover for short-term protection

Standards and Regulations

Flammability rating according to UL 94	HB
----------------------------------------	----

Environmental Product Compliance

China RoHS	Environmentally friendly use period: unlimited = EFUP-e
	No hazardous substances above threshold values

Drawings

Dimensional drawing

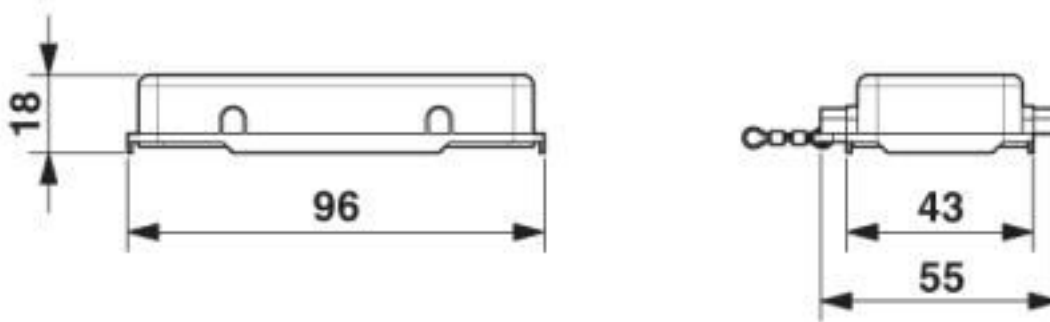

Dimensional drawing

Classifications

eCl@ss

eCl@ss 10.0.1	27440208
eCl@ss 4.0	27140800
eCl@ss 4.1	27140800
eCl@ss 5.0	27142100
eCl@ss 5.1	27142100
eCl@ss 6.0	27261200

Protective covers - HC-B 16-SD-FQ/FS - 1772599

Classifications

eCl@ss

eCl@ss 7.0	27440208
eCl@ss 8.0	27440208
eCl@ss 9.0	27440208

ETIM

ETIM 2.0	EC000437
ETIM 3.0	EC000437
ETIM 4.0	EC000437
ETIM 5.0	EC002314
ETIM 6.0	EC002314
ETIM 7.0	EC002314

UNSPSC

UNSPSC 6.01	30212113
UNSPSC 7.0901	39121712
UNSPSC 11	39121712
UNSPSC 12.01	39121712
UNSPSC 13.2	39121421
UNSPSC 18.0	39121421
UNSPSC 19.0	39121421
UNSPSC 20.0	39121421
UNSPSC 21.0	39121421

Approvals

Approvals

Approvals

EAC

Ex Approvals

Approval details

EAC		RU C- DE.AI30.B.01102
-----	--	--------------------------

