

Housing - HC-B 16-SML-67/M2PG21 - 1771655

Please be informed that the data shown in this PDF Document is generated from our Online Catalog. Please find the complete data in the user's documentation. Our General Terms of Use for Downloads are valid (<http://phoenixcontact.com/download>)



Box mounting base, with single locking latch, height 67 mm, with screw connection, 2x Pg21



Key Commercial Data

Packing unit	1 pc
Minimum order quantity	10 pc
GTIN	 4 017918 036379
GTIN	4017918036379
Weight per Piece (excluding packing)	389.730 g
Custom tariff number	85389099
Country of origin	Germany

Technical data

Dimensions

Height	67 mm
Width	57 mm
Length	117 mm
Wrench size, union nut	28 mm
External cable diameter	10 mm ... 19 mm (Cable 1)
	10 mm ... 19 mm (Cable 2)

Ambient conditions

Degree of protection of housing (IP)	IP65
Ambient temperature (operation)	-40 °C ... 125 °C

Housing - HC-B 16-SML-67/M2PG21 - 1771655

Technical data

General

Note	For contact inserts HC-B16, BB32, BBB40, D40, DD72, HS6, M, K
Size	B16
Housing type	Box mounting bases
Locking type	with single locking latch
No. of cable outlets	2
Cable outlet	lateral
Screw connection	with
Type of the screw connection	2x Pg21
Housing material	Aluminum die-cast
Housing surface material	Powder-coated, gray
Seal material	NBR
Cable gland material	Nickel-plated brass
Cable seal material	NBR
Material lock	Stainless steel, handle: PA
Material grip body interlock	PA

Environmental Product Compliance

China RoHS	Environmentally friendly use period: unlimited = EFUP-e
	No hazardous substances above threshold values

Drawings

Housing - HC-B 16-SML-67/M2PG21 - 1771655

Dimensional drawing

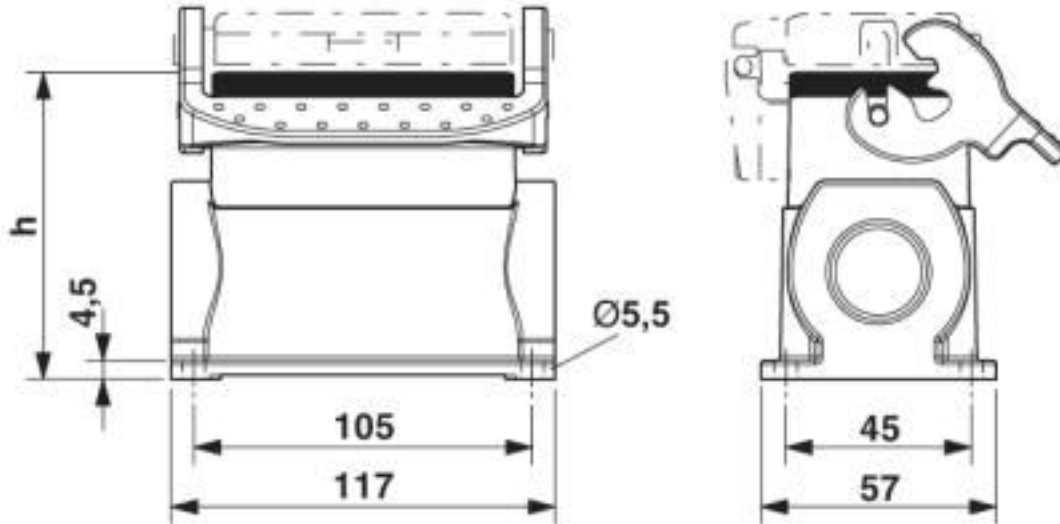

Dimensional drawing

Classifications

eCl@ss

eCl@ss 10.0.1	27440202
eCl@ss 4.0	27140800
eCl@ss 4.1	27140800
eCl@ss 5.0	27143400
eCl@ss 5.1	27261200
eCl@ss 6.0	27261200
eCl@ss 7.0	27440202
eCl@ss 8.0	27440202
eCl@ss 9.0	27440202

ETIM

ETIM 2.0	EC000437
ETIM 3.0	EC000437
ETIM 4.0	EC000437
ETIM 5.0	EC000437
ETIM 6.0	EC000437
ETIM 7.0	EC000437

Housing - HC-B 16-SML-67/M2PG21 - 1771655

Classifications

UNSPSC

UNSPSC 6.01	31261502
UNSPSC 7.0901	31261502
UNSPSC 11	31261502
UNSPSC 12.01	31261502
UNSPSC 13.2	31261501
UNSPSC 18.0	31261501
UNSPSC 19.0	31261501
UNSPSC 20.0	31261501
UNSPSC 21.0	31261501

Approvals

Approvals

Approvals

EAC

Ex Approvals

Approval details

EAC		RU C- DE.AI30.B.01102
-----	---	--------------------------
