

Housing - HC-B 10-SML-52/M1PG16 - 1771383

Please be informed that the data shown in this PDF Document is generated from our Online Catalog. Please find the complete data in the user's documentation. Our General Terms of Use for Downloads are valid (<http://phoenixcontact.com/download>)



Box mounting base, with single locking latch, height 52 mm, with screw connection, 1x Pg16



Key Commercial Data

Packing unit	1 pc
Minimum order quantity	10 pc
GTIN	 4 017918 036119
GTIN	4017918036119
Weight per Piece (excluding packing)	241.000 g
Custom tariff number	85389099
Country of origin	Germany

Technical data

Dimensions

Height	52 mm
Width	52 mm
Length	93 mm
Wrench size, union nut	22 mm
External cable diameter	7.5 mm ... 15 mm

Ambient conditions

Degree of protection of housing (IP)	IP65
Ambient temperature (operation)	-40 °C ... 125 °C

General

Housing - HC-B 10-SML-52/M1PG16 - 1771383

Technical data

General

Size	B10
Housing type	Box mounting bases
Locking type	with single locking latch
No. of cable outlets	1
Cable outlet	left (view of the opened single locking latch)
Screw connection	with
Type of the screw connection	1x Pg16
Housing material	Aluminum die-cast
Housing surface material	Powder-coated, gray
Seal material	NBR
Cable gland material	Nickel-plated brass
Cable seal material	NBR
Material lock	Stainless steel, handle: PA
Material grip body interlock	PA

Environmental Product Compliance

China RoHS	Environmentally friendly use period: unlimited = EFUP-e
	No hazardous substances above threshold values

Drawings

Dimensional drawing

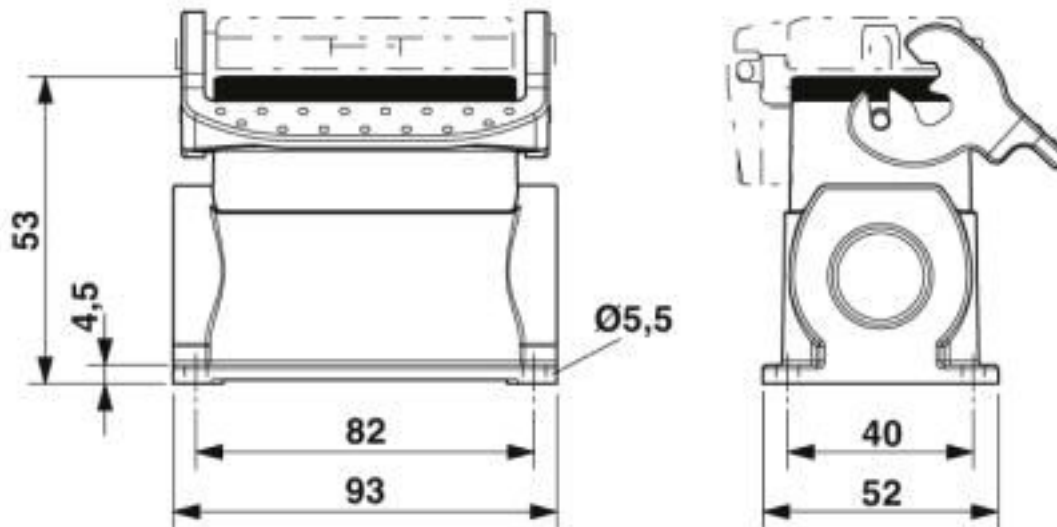

Dimensional drawing

Housing - HC-B 10-SML-52/M1PG16 - 1771383

Classifications

eCl@ss

eCl@ss 10.0.1	27440202
eCl@ss 4.0	27140800
eCl@ss 4.1	27140800
eCl@ss 5.0	27143400
eCl@ss 5.1	27261200
eCl@ss 6.0	27261200
eCl@ss 7.0	27440202
eCl@ss 8.0	27440202
eCl@ss 9.0	27440202

ETIM

ETIM 2.0	EC000437
ETIM 3.0	EC000437
ETIM 4.0	EC000437
ETIM 5.0	EC000437
ETIM 6.0	EC000437
ETIM 7.0	EC000437

UNSPSC

UNSPSC 6.01	31261502
UNSPSC 7.0901	31261502
UNSPSC 11	31261502
UNSPSC 12.01	31261502
UNSPSC 13.2	31261501
UNSPSC 18.0	31261501
UNSPSC 19.0	31261501
UNSPSC 20.0	31261501
UNSPSC 21.0	31261501

Approvals

Approvals

Approvals

EAC

Ex Approvals

Housing - HC-B 10-SML-52/M1PG16 - 1771383

Approvals

Approval details

EAC



RU C-
DE.AI30.B.01102