

D-SUB panel mounting frames - VS-25-A-DEVNET-S - 1652253

Please be informed that the data shown in this PDF Document is generated from our Online Catalog. Please find the complete data in the user's documentation. Our General Terms of Use for Downloads are valid (<http://phoenixcontact.com/download>)



D-SUB panel mounting frame, for DeviceNet, shell size 3, header, screw connection, unshielded, connection direction straight, IP67 degree of protection



Key Commercial Data

Packing unit	1 pc
GTIN	 4 017918 929152
GTIN	4017918929152
Weight per Piece (excluding packing)	23.100 g
Custom tariff number	85369010
Country of origin	Germany

Technical data

Mechanical characteristics

Connection method	Screw connection
Overvoltage category	III
AWG solid min.	24
AWG solid max.	12
Degree of pollution	3
Conductor cross section	0.2 mm ² ... 2.5 mm ²
Weight	23.1 g
Flammability rating according to UL 94	V0

Ambient conditions

Ambient temperature (operation)	-40 °C ... 80 °C
---------------------------------	------------------

D-SUB panel mounting frames - VS-25-A-DEVNET-S - 1652253

Technical data

Material data

Contact surface material	gold-plated
Contact material	Cu alloy
Contact carrier material	PBT
Housing material	PA
Width	30.5 mm
Height	24 mm
Length	76 mm

Electrical characteristics

Number of positions	5
Rated current	8 A
Overvoltage category	III
Degree of pollution	3
Rated voltage (III/3)	250 V

Standards and Regulations

Flammability rating according to UL 94	V0
Safety note	WARNING: The connectors may not be plugged in or disconnected under load. Ignoring the warning or improper use may damage persons and/or property.
	<ul style="list-style-type: none"> • WARNING: Commission properly functioning products only. The products must be regularly inspected for damage. Decommission defective products immediately. Replace damaged products. Repairs are not possible.
	<ul style="list-style-type: none"> • WARNING: Only electrically qualified personnel may install and operate the product. They must observe the following safety notes. The qualified personnel must be familiar with the basics of electrical engineering. They must be able to recognize and prevent danger. The relevant symbol on the packaging indicates that only personnel familiar with electrical engineering are allowed to install and operate the product.
	<ul style="list-style-type: none"> • The products are suitable for applications in plant, controller, and electrical device engineering.
	<ul style="list-style-type: none"> • When operating the connectors in outdoor applications, they must be separately protected against environmental influences.
	<ul style="list-style-type: none"> • Assembled products may not be manipulated or improperly opened.
	<ul style="list-style-type: none"> • Only use mating connectors that are specified in the technical data of the standards listed (e.g. the ones listed in the product accessories online at phoenixcontact.com/products).
	<ul style="list-style-type: none"> • When using the product in direct connection with third-party manufacturers, the user is responsible.
	<ul style="list-style-type: none"> • For operating voltages > 50 V AC, conductive connector housings must be grounded
	<ul style="list-style-type: none"> • Only use tools recommended by Phoenix Contact
	<ul style="list-style-type: none"> • The installation notes/Design In documents online on the download page at phoenixcontact.com/products must be observed for this product.

D-SUB panel mounting frames - VS-25-A-DEVNET-S - 1652253

Technical data

Standards and Regulations

	<ul style="list-style-type: none"> • Use a protective cap to protect connectors that are not in use. The suitable accessories are available online in the accessory section of the product at phoenixcontact.com/products
	<ul style="list-style-type: none"> • Operate the connector only when it is fully plugged in and interlocked.
	<ul style="list-style-type: none"> • Operate the connector only when it is fully plugged in.
	<ul style="list-style-type: none"> • Ensure that when laying the cable, the tensile load on the connectors does not exceed the upper limit specified in the standards.
	<ul style="list-style-type: none"> • Observe the minimum bending radius of the cable. Lay the cable without twisting it.
	<ul style="list-style-type: none"> • VDE 0100/1.97 § 411.1.3.2 and DIN EN 60 204/11.98 § 14.1.3 are applicable when combining several circuits in a cable and/or connector

Environmental Product Compliance

REACH SVHC	Lead 7439-92-1
China RoHS	Environmentally Friendly Use Period = 50 years
	For details about hazardous substances go to tab "Downloads", Category "Manufacturer's declaration"

Drawings

D-SUB panel mounting frames - VS-25-A-DEVNET-S - 1652253

Dimensional drawing

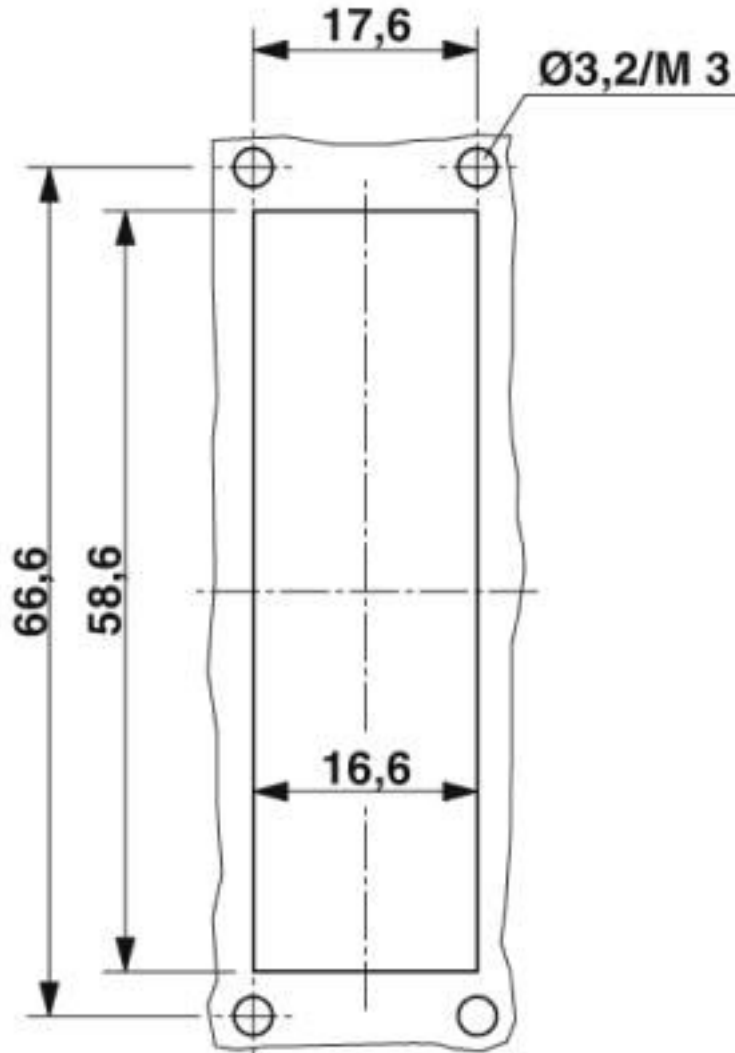

Panel cutout: VS-25-A...

D-SUB panel mounting frames - VS-25-A-DEVNET-S - 1652253

Dimensional drawing

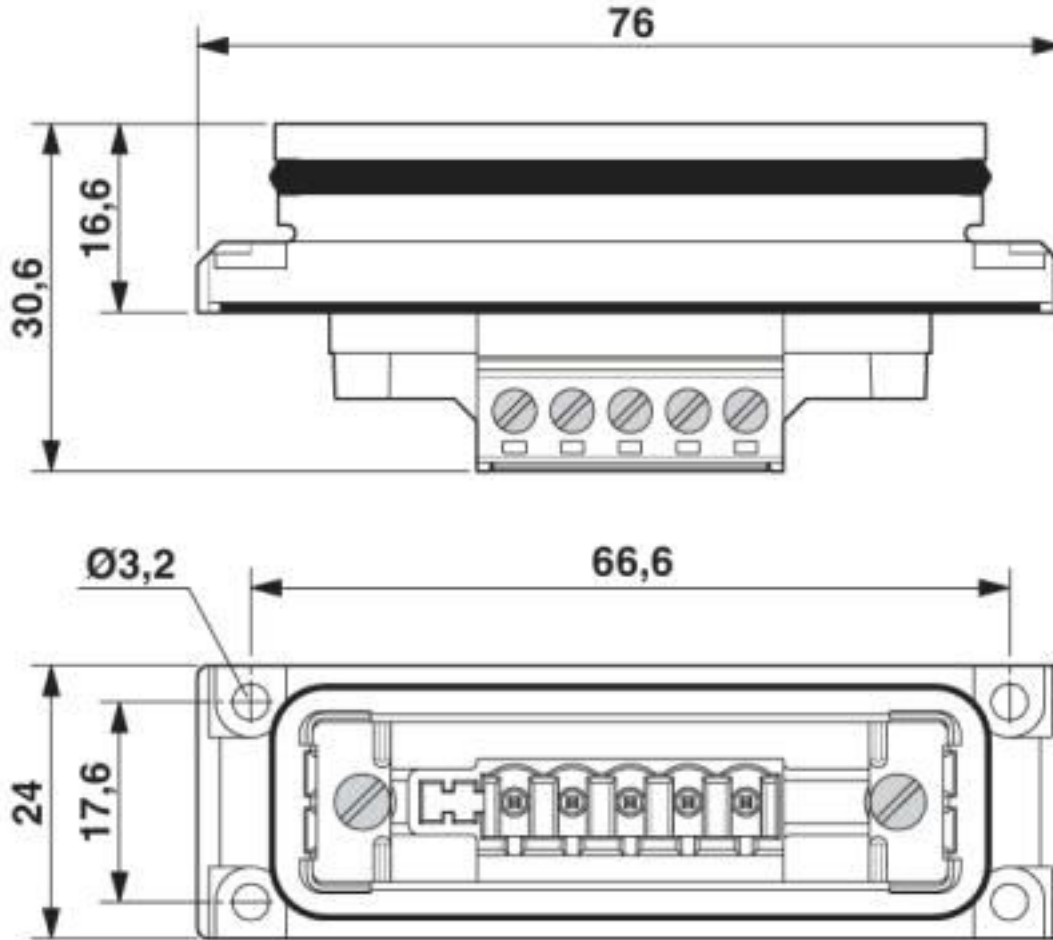

D-SUB panel mounting frame

Classifications

eCl@ss

eCl@ss 10.0.1	27440210
eCl@ss 4.0	27260700
eCl@ss 4.1	27260700
eCl@ss 5.0	27260700
eCl@ss 5.1	27260700
eCl@ss 6.0	27261200
eCl@ss 7.0	27440210
eCl@ss 8.0	27440210

D-SUB panel mounting frames - VS-25-A-DEVNET-S - 1652253

Classifications

eCl@ss

eCl@ss 9.0	27440210
------------	----------

ETIM

ETIM 2.0	EC000437
ETIM 3.0	EC000437
ETIM 4.0	EC000437
ETIM 5.0	EC002310
ETIM 6.0	EC002310
ETIM 7.0	EC002310

UNSPSC

UNSPSC 6.01	31261501
UNSPSC 7.0901	31261501
UNSPSC 11	31261501
UNSPSC 12.01	31261501
UNSPSC 13.2	39121421
UNSPSC 18.0	39121421
UNSPSC 19.0	39121421
UNSPSC 20.0	39121421
UNSPSC 21.0	39121421

Approvals

Approvals

Approvals

EAC

Ex Approvals

Approval details

EAC		B.01687
-----	--	---------

D-SUB panel mounting frames - VS-25-A-DEVNET-S - 1652253

Accessories

Accessories

Protective cover

D-SUB protective cover - VS-25-SD - 1652211

D-SUB protective cover, shell size 3, IP54 degree of protection, for panel mounting frame and sleeve housing VS-25...



Phoenix Contact 2020 © - all rights reserved
<http://www.phoenixcontact.com>