

## Device connector, front mounting - CA-16P1N126L00 - 1624053

Please be informed that the data shown in this PDF Document is generated from our Online Catalog. Please find the complete data in the user's documentation. Our General Terms of Use for Downloads are valid (<http://phoenixcontact.com/download>)



Device connector for front wall, CA, straight, shielded: yes, for standard and SPEEDCON interlock, M23, No. of pos.: 16, type of contact: Pin, Solder connection, Axial seal, Central fastening M20 x 1.5, can be positioned via a locking nut

The figure shows the 12-pos. product version

### Your advantages

- ✓ Safe use in the field, thanks to high degree of protection
- ✓ Connector for flexible on-site assembly
- ✓ Consistent EMC protection for reliable transmission of signals
- ✓ Solder connection: proven connection technology for various litz wires

### Key Commercial Data

Packing unit	1 pc
GTIN	
GTIN	4055626227740
Custom tariff number	85366990
Country of origin	Germany

### Technical data

#### Data of the insulating body

Coding	N
Insulator material	PBT
Contact material	CuZn
Contact surface material	Ni/Au
Insertion/withdrawal cycles mechanical	100
Contact connection method	Solder connection

## Device connector, front mounting - CA-16P1N126L00 - 1624053

### Technical data

#### Data of the insulating body

Type of contacts	Pin
Application	Signal
Number of positions	16
Direction of rotation	Standard
Contact diameter of signal contacts	1 mm
Litz wire cross section of signal contacts max.	1 mm <sup>2</sup>
Nominal current per signal contact	8 A
Rated voltage of signal contact	150 V
Rated surge voltage	1.5 kV
Overvoltage category	II
Degree of pollution	3

#### Housing data

Housing material	Turned parts: copper zinc alloy (CuZn), die-cast parts: zinc (GD-Zn)
Type of locking	for standard and SPEEDCON interlock
Degree of protection (when plugged in)	IP67
Thread type	M23

#### Environmental Product Compliance

REACH SVHC	Lead 7439-92-1
China RoHS	Environmentally Friendly Use Period = 50 years
	For details about hazardous substances go to tab "Downloads", Category "Manufacturer's declaration"

### Drawings

# Device connector, front mounting - CA-16P1N126L00 - 1624053

Schematic diagram

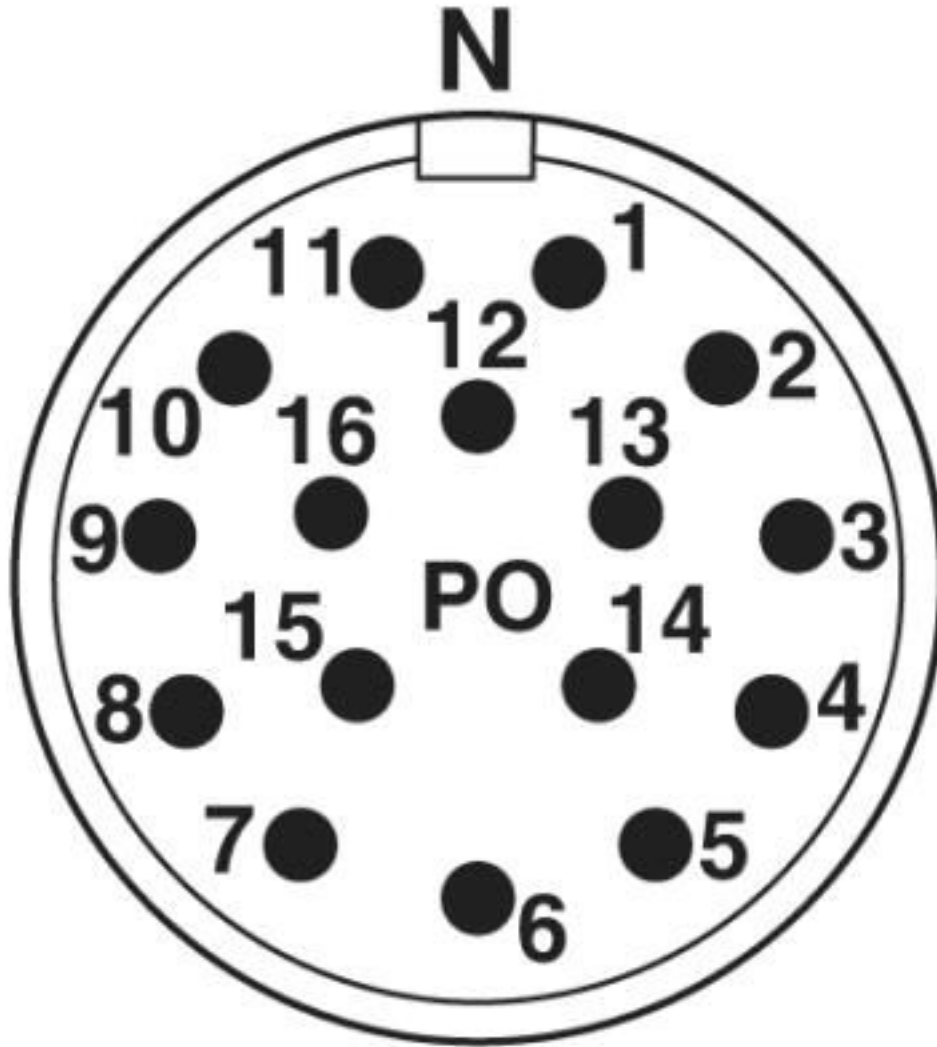

# Device connector, front mounting - CA-16P1N126L00 - 1624053

Dimensional drawing

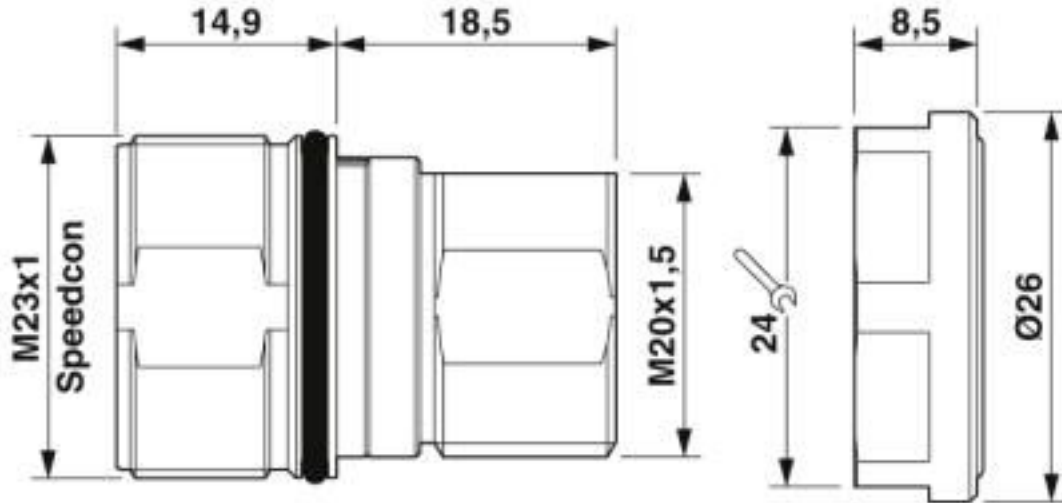

Dimensional drawing

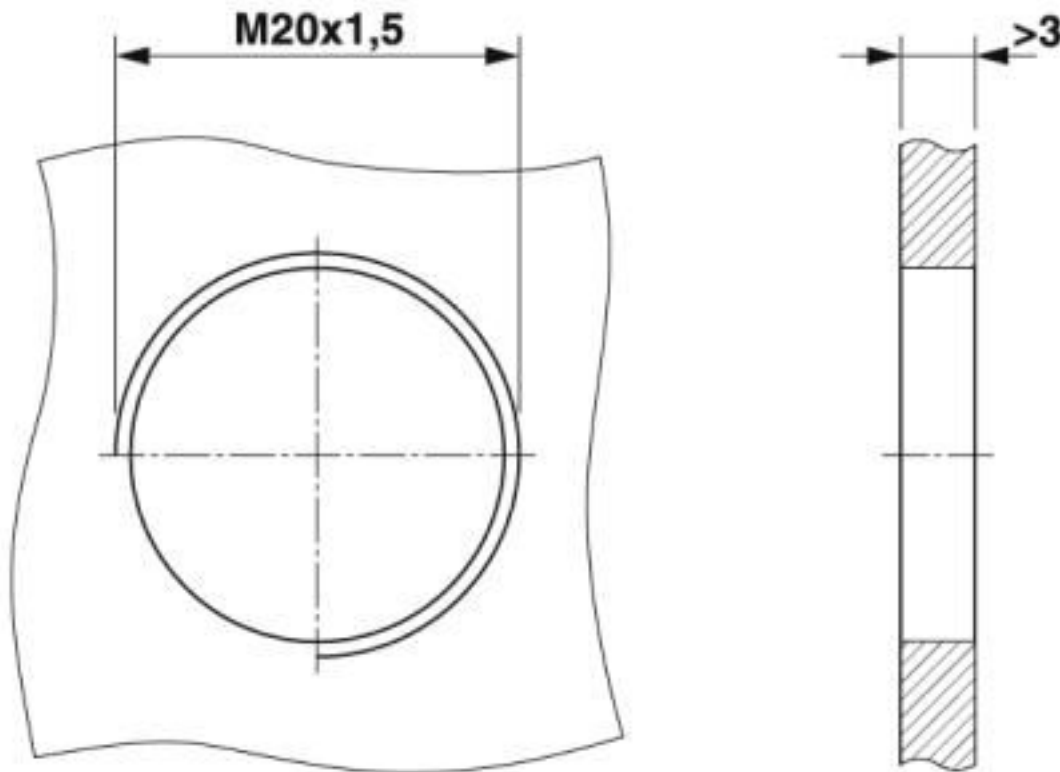

Installation dimensions

# Device connector, front mounting - CA-16P1N126L00 - 1624053

## Classifications

### eCl@ss

eCl@ss 10.0.1	27440109
eCl@ss 4.0	27260700
eCl@ss 4.1	27260700
eCl@ss 5.0	27260700
eCl@ss 5.1	27260700
eCl@ss 6.0	27260700
eCl@ss 7.0	27440102
eCl@ss 8.0	27440102
eCl@ss 9.0	27440103

### ETIM

ETIM 5.0	EC002635
ETIM 6.0	EC002061

### UNSPSC

UNSPSC 13.2	39121413
UNSPSC 18.0	39121413
UNSPSC 19.0	39121413
UNSPSC 20.0	39121413
UNSPSC 21.0	39121413

## Approvals

### Approvals

Approvals

EAC

Ex Approvals

### Approval details

EAC		B.01687
-----	--	---------

## Device connector, front mounting - CA-16P1N126L00 - 1624053

### Accessories

Accessories

Mounting material

Contact removal tool - CA-Z0001 - 1620699



Unlocking tool for contact carriers for snapping in the M23 signal device connectors

---

Color-coding - RF-Z0017 - 1620624



Color-coding, color: green

---

Color-coding - RF-Z0018 - 1620625



Color-coding, color: orange

---

Color-coding - RF-Z0019 - 1620626



Color-coding, color: anthracite

---

Protective cover

## Device connector, front mounting - CA-16P1N126L00 - 1624053

### Accessories

Protective cap - SF-Z0019 - 1607449



Plastic protection cap, with eye, IP40 for connectors with M23 external thread, RF, SF series

---

Protective cap - RC-Z2059 - 1604225



Plastic protection cap for connectors with M23 external thread

---

Plastic anti-static dust protection cap - RC-Z2469 - 1611797



Plastic protection cap, antistatic, for RF, SF, CA, RC series connectors, with M23 external thread

---

Metal protective cap - RC-Z2104 - 1604260



Metal protection cap for signal connectors with M23 external thread

---

Metal protective cap - RC-Z2068 - 1604236



Metal protection cap with steel wire for signal connectors with M23 external thread

---

---

