

Device connector, front mounting - RF-17P1N8AA200 - 1607327

Please be informed that the data shown in this PDF Document is generated from our Online Catalog. Please find the complete data in the user's documentation. Our General Terms of Use for Downloads are valid (<http://phoenixcontact.com/download>)



Device connector, front mounting, angled fixed, Screw locking, M23, number of positions: 17, type of contact: Pin, Crimp connection, Axial O-ring, 4x Ø 3.2, shielded: yes, flange dimensions: 26 mm x 26 mm

The figure shows the 12-pos. product version



Key Commercial Data

Packing unit	1 pc
GTIN	
GTIN	4046356269032
Weight per Piece (excluding packing)	99.490 g
Custom tariff number	85366990
Country of origin	Germany

Technical data

Environmental Product Compliance

REACH SVHC	Lead 7439-92-1
China RoHS	Environmentally Friendly Use Period = 50 years
	For details about hazardous substances go to tab "Downloads", Category "Manufacturer's declaration"

Drawings

Device connector, front mounting - RF-17P1N8AA200 - 1607327

Dimensional drawing

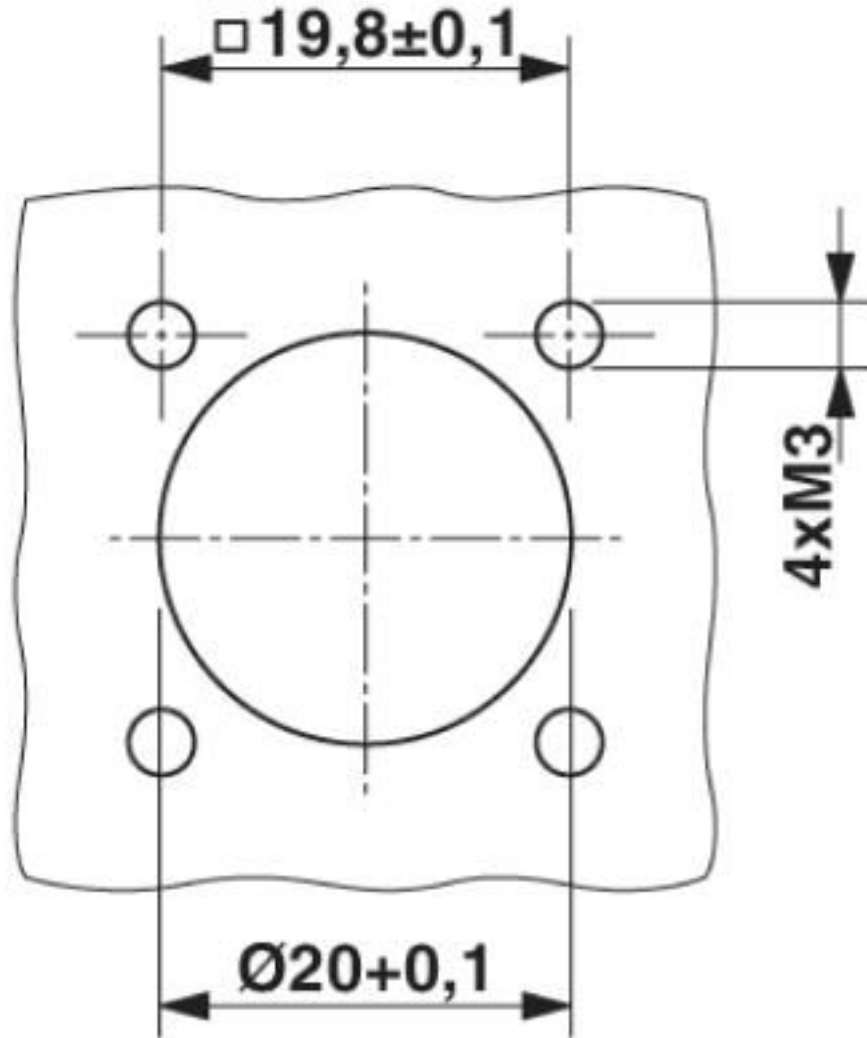

Device connector, front mounting - RF-17P1N8AA200 - 1607327

Schematic diagram

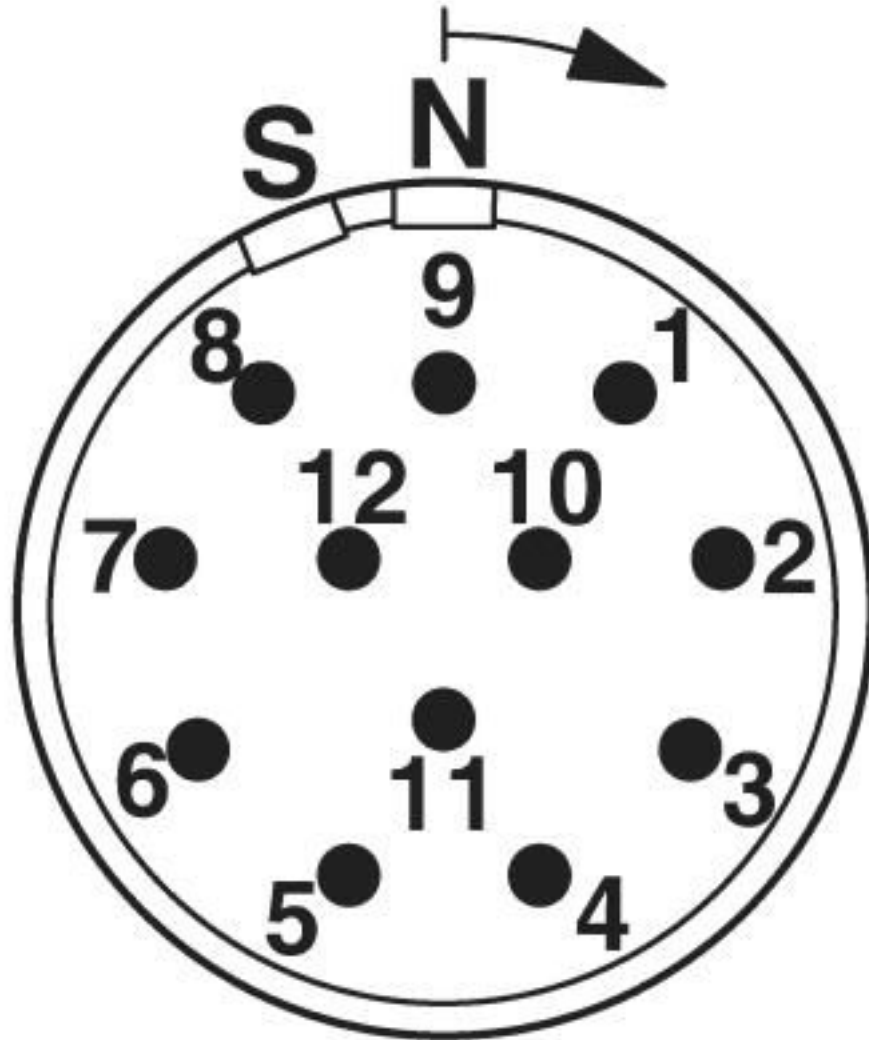

Device connector, front mounting - RF-17P1N8AA200 - 1607327

Dimensional drawing

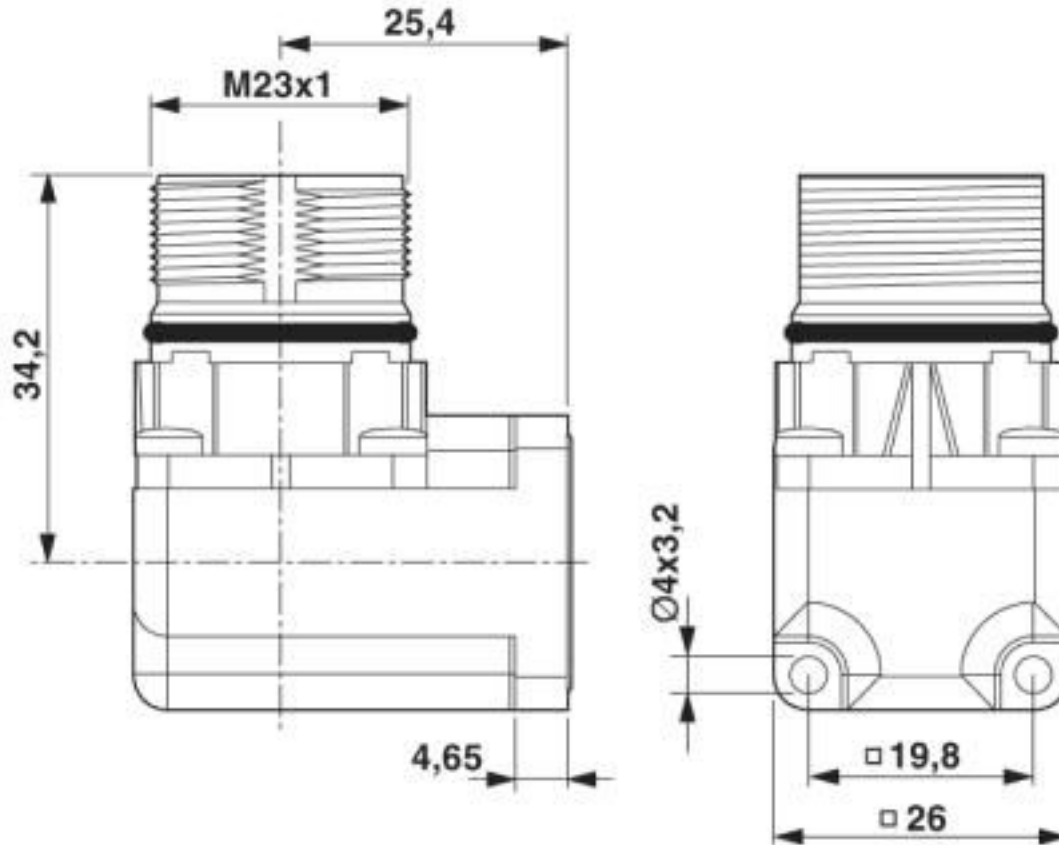

Classifications

eCl@ss

eCl@ss 10.0.1	27440109
eCl@ss 4.0	27260700
eCl@ss 4.1	27260700
eCl@ss 5.0	27260700
eCl@ss 5.1	27260700
eCl@ss 6.0	27260700
eCl@ss 7.0	27440102
eCl@ss 8.0	27440102
eCl@ss 9.0	27440103

ETIM

ETIM 3.0	EC001121
ETIM 4.0	EC001121

Device connector, front mounting - RF-17P1N8AA200 - 1607327

Classifications

ETIM

ETIM 5.0	EC002635
ETIM 6.0	EC002061

UNSPSC

UNSPSC 6.01	43172015
UNSPSC 7.0901	43201404
UNSPSC 11	43172015
UNSPSC 12.01	43201404
UNSPSC 13.2	39121413
UNSPSC 18.0	39121413
UNSPSC 19.0	39121413
UNSPSC 20.0	39121413
UNSPSC 21.0	39121413

Approvals

Approvals

Approvals

UL Recognized / cUL Recognized / EAC / cULus Recognized

Ex Approvals

Approval details

UL Recognized		http://database.ul.com/cgi-bin/XYV/template/LISEXT/1FRAME/index.htm	FILE E 153698
Nominal voltage UN	125 V		
Nominal current IN	1 A		
mm ² /AWG/kcmil	26		

Device connector, front mounting - RF-17P1N8AA200 - 1607327

Approvals

cUL Recognized		http://database.ul.com/cgi-bin/XYV/template/LISEXT/1FRAME/index.htm	FILE E 153698
Nominal voltage UN		125 V	
Nominal current IN		1 A	
mm ² /AWG/kcmil		26	

EAC		B.01687
-----	---	---------

cULus Recognized	
------------------	---