

Mounting flange - HC-B-AF-SET - 1604638

Please be informed that the data shown in this PDF Document is generated from our Online Catalog. Please find the complete data in the user's documentation. Our General Terms of Use for Downloads are valid (<http://phoenixcontact.com/download>)

Panel mounting flange for screw locking, set comprising 2 panel mounting flanges with 4 self-tapping screws (M4, Torx®) and 4 fan-type washers



COMPLETE™

Key Commercial Data

Packing unit	1 pc
GTIN	 4 017918 893262
GTIN	4017918893262
Weight per Piece (excluding packing)	20.000 g
Custom tariff number	85389099
Country of origin	China

Technical data

Dimensions

Width	42 mm
Height	20.5 mm

Ambient conditions

Ambient temperature (operation)	-40 °C ... 125 °C
---------------------------------	-------------------

General

Size	B6 - B24
Pg screw connection	none
Material	Aluminum, die-cast
Note	1 for every connector

Mounting flange - HC-B-AF-SET - 1604638

Technical data

General

Assembly instructions	In order to guarantee that the ground conductor contact functions even when plugged in at an angle, the two panel mounting flanges must have sufficient electrical contact with the metal mounting panel.
Connection	Minimum panel thickness of a steel sheet: 2.0 mm. For mounting with self-tapping M4 screws: 3.6 mm drill-hole diameter

Environmental Product Compliance

China RoHS	Environmentally friendly use period: unlimited = EFUP-e
	No hazardous substances above threshold values

Drawings

Dimensional drawing

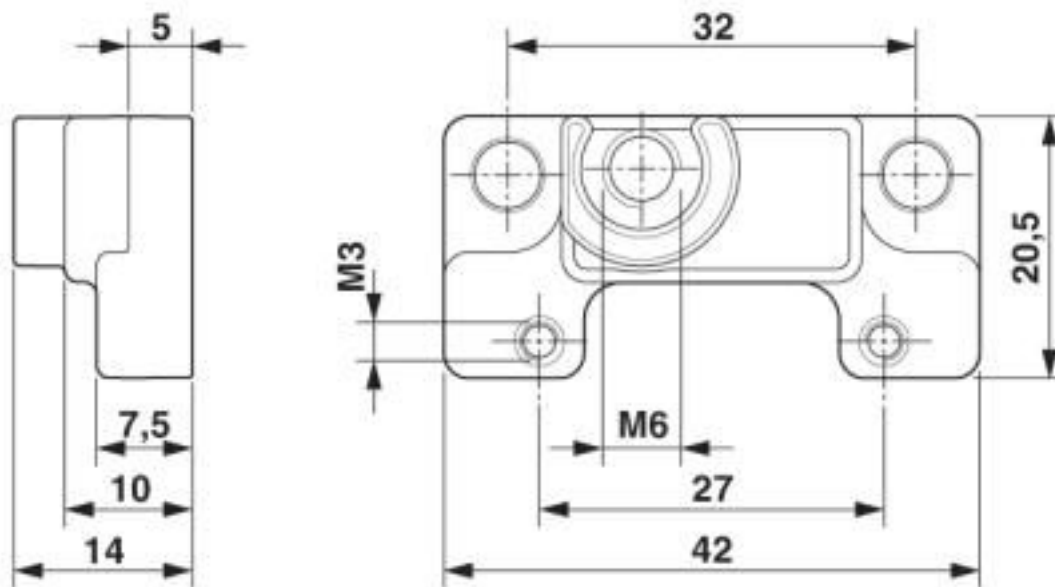

Dimensional drawing

Classifications

eCl@ss

eCl@ss 10.0.1	27440192
eCl@ss 4.0	27260700
eCl@ss 4.1	27140800
eCl@ss 5.0	27371200
eCl@ss 5.1	27371200

Mounting flange - HC-B-AF-SET - 1604638

Classifications

eCl@ss

eCl@ss 6.0	27261200
eCl@ss 7.0	27440210
eCl@ss 8.0	27440210
eCl@ss 9.0	27440192

ETIM

ETIM 2.0	EC000437
ETIM 3.0	EC000437
ETIM 4.0	EC000437
ETIM 5.0	EC002310
ETIM 6.0	EC002310
ETIM 7.0	EC002310

UNSPSC

UNSPSC 6.01	31261502
UNSPSC 7.0901	31261502
UNSPSC 11	31261502
UNSPSC 12.01	31261502
UNSPSC 13.2	39121421
UNSPSC 18.0	39121421
UNSPSC 19.0	39121421
UNSPSC 20.0	39121421
UNSPSC 21.0	39121421