

Housing - HC-B 24-SMQ-67/M2M25 - 1586989

Please be informed that the data shown in this PDF Document is generated from our Online Catalog. Please find the complete data in the user's documentation. Our General Terms of Use for Downloads are valid (<http://phoenixcontact.com/download>)



Box mounting base, with double locking latch, height 67 mm, with screw connection, 2x M25



Key Commercial Data

Packing unit	1
GTIN	 4 046356 427074
GTIN	4046356427074
Custom tariff number	85389099

Technical data

Dimensions

Height	67 mm
Width	57 mm
Length	144 mm
Wrench size, union nut	25 mm
External cable diameter	9 mm ... 18 mm (Cable 1)
	9 mm ... 18 mm (Cable 2)

Ambient conditions

Degree of protection of housing (IP)	IP65
Ambient temperature (operation)	-40 °C ... 125 °C

General

Note	For contact inserts HC-B24, BB46, BBB64, D64, DD108, M
Size	B24

Housing - HC-B 24-SMQ-67/M2M25 - 1586989

Technical data

General

Housing type	Box mounting bases
Locking type	with double locking latch
No. of cable outlets	2
Cable outlet	lateral
Screw connection	with
Type of the screw connection	2x M25
Housing material	Aluminum die-cast
Housing surface material	Powder-coated, gray
Seal material	NBR
Cable gland material	Nickel-plated brass
Cable seal material	NBR
Material lock	Stainless steel, handle: PA
Material grip body interlock	PA

Environmental Product Compliance

China RoHS	Environmentally friendly use period: unlimited = EFUP-e
	No hazardous substances above threshold values

Drawings

Dimensional drawing

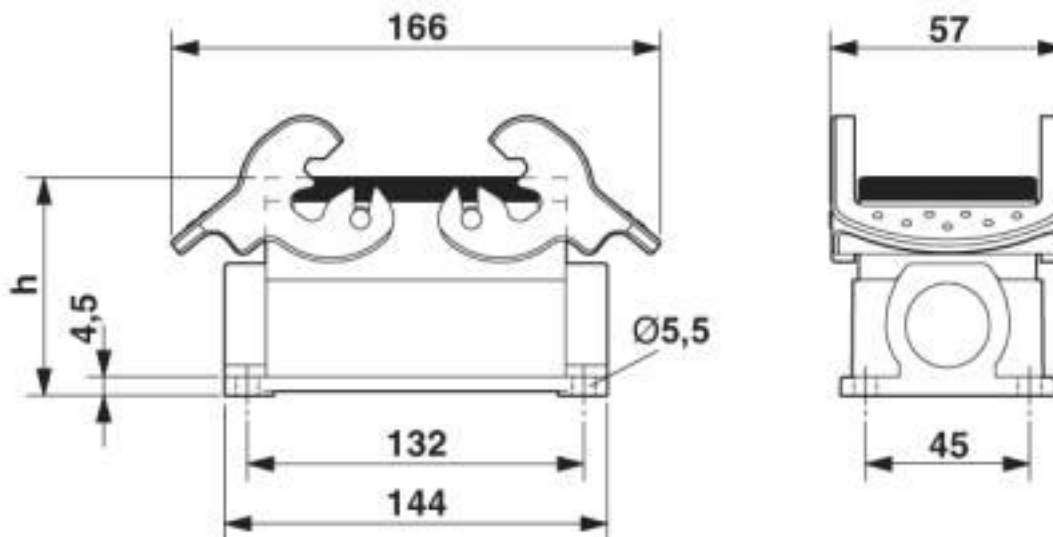

Dimensional drawing

Housing - HC-B 24-SMQ-67/M2M25 - 1586989

Classifications

eCl@ss

eCl@ss 10.0.1	27440202
eCl@ss 4.0	27140800
eCl@ss 4.1	27140800
eCl@ss 5.0	27143400
eCl@ss 5.1	27261200
eCl@ss 6.0	27261200
eCl@ss 7.0	27440202
eCl@ss 8.0	27440202
eCl@ss 9.0	27440202

ETIM

ETIM 3.0	EC000437
ETIM 4.0	EC000437
ETIM 5.0	EC000437
ETIM 6.0	EC000437
ETIM 7.0	EC000437

UNSPSC

UNSPSC 6.01	31261502
UNSPSC 7.0901	31261502
UNSPSC 11	31261502
UNSPSC 12.01	31261502
UNSPSC 13.2	31261501
UNSPSC 18.0	31261501
UNSPSC 19.0	31261501
UNSPSC 20.0	31261501
UNSPSC 21.0	31261501

Approvals

Approvals

Approvals

EAC / EAC

Ex Approvals

Housing - HC-B 24-SMQ-67/M2M25 - 1586989

Approvals

Approval details

EAC		RU C- DE.AI30.B.01102
-----	--	--------------------------

EAC		RU C- DE.AI30.B.01102
-----	--	--------------------------

Accessories

Accessories

Full screw connection

Cable gland - HC-K-KV-M25(11-17) - 1690639



Plastic screw connection up to 5 bar, thread length: 8 mm, cable diameter: 11 - 17 mm, WAF 29, screw connection: M25

Cable gland - HC-M-KV-M25(14-21) - 1646007



Metal screw connection up to 5 bar, thread length: 7 mm, cable diameter: 14 - 21 mm, WAF 34, screw connection: M25

Cable gland - HC-M-KV-M25(1ASI) - 1584020



Metal screw connection for an AS-Interface flat-ribbon conductor, thread type M25

Multiple screw connection

Housing - HC-B 24-SMQ-67/M2M25 - 1586989

Accessories

Cable gland - HC-M-KV-M25(1X10/1X11) - 1580228



Special cable screw connection M25, brass nickel-plated, grommet with 10 mm and 11 mm holes
