

Cable gland - G-INS-M20-M68L-PEPDS-LG - 1424515

Please be informed that the data shown in this PDF Document is generated from our Online Catalog. Please find the complete data in the user's documentation. Our General Terms of Use for Downloads are valid (<http://phoenixcontact.com/download>)



Cable gland, cable gland material: PA, external cable diameter 6 mm ... 13 mm, shielding: no, connecting thread: M20 x 1.5, color: lightgrey RAL 7035



Key Commercial Data

Packing unit	1 pc
Minimum order quantity	5 pc
GTIN	 4 055626 374208
GTIN	4055626374208
Custom tariff number	39269097
Country of origin	Germany

Technical data

Dimensions

Length	41 mm
Wrench size, union nut	24 mm
Wrench size, support	24 mm
Hexagon angular dimension	27 mm
Length of the connecting thread	15 mm
Feed-through hole diameter	20.1 mm ... 20.2 mm
External cable diameter	6 mm ... 13 mm
	7.5 mm ... 11.3 mm (UL)

Ambient conditions

Degree of protection (IP)	IP68 (5 bar / 0.5 h)
	IP69

Cable gland - G-INS-M20-M68L-PEPDS-LG - 1424515

Technical data

Ambient conditions

Ambient temperature (operation)	-40 °C ... 100 °C (static)
---------------------------------	----------------------------

General

No. of conductors	1
Cable gland material	PA
Cable seal material	EPDM
Shielded	no
Thread type on connection side	M20 x 1.5
Torque	Union nut
	4 Nm (Support sleeve)
Color	lightgrey RAL 7035
Impact category	2
Execution of the strain relief	A
Assembly instructions	1) Mount screw connection support in the housing using the correct torque 2) Insert cable 3) Tighten union nut using the correct torque
Manufacturer	WISKA
Manufacturer Designation	ESKV-L 20

Environmental Product Compliance

China RoHS	Environmentally friendly use period: unlimited = EFUP-e
	No hazardous substances above threshold values

Drawings

Cable gland - G-INS-M20-M68L-PEPDS-LG - 1424515

Dimensional drawing

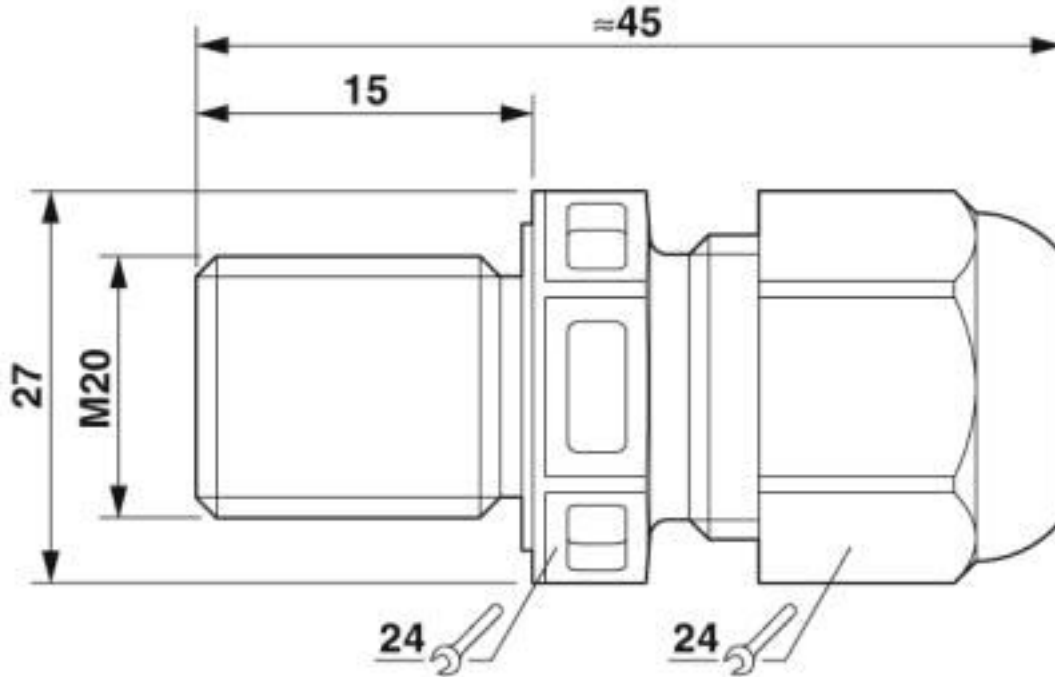

Classifications

eCl@ss

eCl@ss 10.0.1	27144432
eCl@ss 4.0	27141200
eCl@ss 4.1	27141200
eCl@ss 5.0	27149100
eCl@ss 5.1	27149109
eCl@ss 6.0	27149100
eCl@ss 7.0	27149109
eCl@ss 8.0	27149109
eCl@ss 9.0	27144432

ETIM

ETIM 5.0	EC000441
ETIM 6.0	EC000441
ETIM 7.0	EC000441

Approvals

Approvals

Cable gland - G-INS-M20-M68L-PEPDS-LG - 1424515

Approvals

Approvals

UL Recognized / cUL Recognized / cULus Recognized

Ex Approvals

Approval details

UL Recognized		http://database.ul.com/cgi-bin/XYV/template/LISEXT/1FRAME/index.htm	E179850
---------------	---	---	---------

cUL Recognized		http://database.ul.com/cgi-bin/XYV/template/LISEXT/1FRAME/index.htm	E179850
----------------	---	---	---------

cULus Recognized			
------------------	---	--	--

Accessories

Accessories

Flat nut

Counter nut - A-INL-M20-P-LG - 1414570



Counter nut, material: PA 6 GF 30, for threads M20 x 1.5, color: lightgrey RAL 7035

Sealing plugs

Cable gland - G-INS-M20-M68L-PEPDS-LG - 1424515

Accessories

Closing cap - SEALING PLUG 9X16 RD - 1400259



Closing cap, material: PA, color: red