

Cable gland - G-INB-M32-M68N-NEPDS-S - 1415184

Please be informed that the data shown in this PDF Document is generated from our Online Catalog. Please find the complete data in the user's documentation. Our General Terms of Use for Downloads are valid (<http://phoenixcontact.com/download>)



Cable gland, cable gland material: Nickel-plated brass, external cable diameter 13 mm ... 21 mm, shielding: no, connecting thread: M32 x 1.5, color: silver, with bend protection sleeve, with O-ring

Your advantages

- Weatherproof sealing material
- Halogen-free

Key Commercial Data

Packing unit	1 pc
GTIN	 4 055626 038155
GTIN	4055626038155
Weight per Piece (excluding packing)	340.000 g
Custom tariff number	74199990
Country of origin	Germany

Technical data

Dimensions

Length	146 mm
Wrench size, union nut	36 mm
Wrench size, support	36 mm
Hexagon angular dimension	40 mm
Length of the connecting thread	8 mm
Feed-through hole diameter	32.1 mm ... 32.3 mm
External cable diameter	13 mm ... 21 mm
	14.6 mm ... 19.5 mm (for UL 514 B)

Cable gland - G-INB-M32-M68N-NEPDS-S - 1415184

Technical data

Ambient conditions

Degree of protection (IP)	IP68 (5 bar / 0.5 h)
	IP69 (DIN EN 60529 / IEC 60529)
Ambient temperature (operation)	-40 °C ... 100 °C (static)

General

Type	with bend protection sleeve
No. of conductors	1
Cable gland material	Nickel-plated brass
Sealing material	EPDM (Cable seal, halogen-free)
Shielded	no
Thread type on connection side	M32 x 1.5
Torque	20 Nm (Union nut: EN 62444)
	20 Nm (Support: EN 62444)
Color	silver
Impact category	6
Execution of the strain relief	A
Manufacturer	WISKA
Manufacturer Designation	EMSKVS 32

Standards and Regulations

Halogen-free	yes
--------------	-----

Environmental Product Compliance

REACH SVHC	Lead 7439-92-1
China RoHS	Environmentally Friendly Use Period = 50 years
	For details about hazardous substances go to tab "Downloads", Category "Manufacturer's declaration"

Drawings

Cable gland - G-INB-M32-M68N-NEPDS-S - 1415184

Dimensional drawing

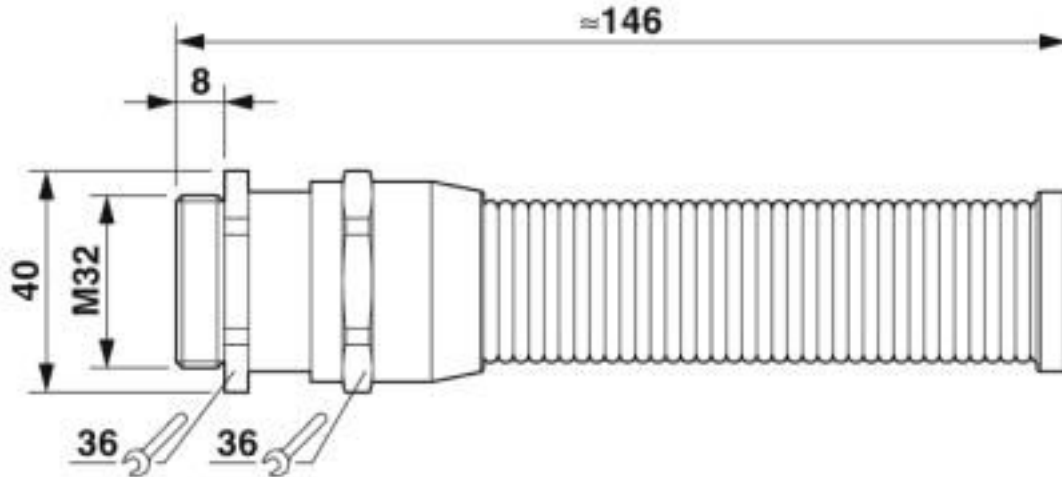

Classifications

eCl@ss

eCl@ss 10.0.1	27144432
eCl@ss 4.0	27141200
eCl@ss 4.1	27141200
eCl@ss 5.0	27149100
eCl@ss 5.1	27149100
eCl@ss 6.0	27149100
eCl@ss 7.0	27149109
eCl@ss 8.0	27149109
eCl@ss 9.0	27144432

ETIM

ETIM 5.0	EC000441
ETIM 6.0	EC000441
ETIM 7.0	EC000441

UNSPSC

UNSPSC 13.2	39121311
UNSPSC 18.0	39121311
UNSPSC 19.0	39121311
UNSPSC 20.0	39121311
UNSPSC 21.0	39121311

Cable gland - G-INB-M32-M68N-NEPDS-S - 1415184

Approvals

Approvals

Approvals

UL Recognized / cUL Recognized / GOST-R / cULus Recognized

Ex Approvals

Approval details

UL Recognized		http://database.ul.com/cgi-bin/XYV/template/LISEXT/1FRAME/index.htm	E179850
---------------	--	---	---------

cUL Recognized		http://database.ul.com/cgi-bin/XYV/template/LISEXT/1FRAME/index.htm	E179850
----------------	--	---	---------

GOST-R			POCC DE.A*98.H12052
--------	--	--	------------------------

cULus Recognized			
------------------	--	--	--

Accessories

Accessories

Flat nut

Counter nut - A-INL-M32-N-S - 1411244



Counter nut, material: Brass, nickel-plated, for threads M32 x 1.5, color: silver

