

Control cabinet feed-through - CUC-BH-M12D1PBK-S/R4BE - 1414398

Please be informed that the data shown in this PDF Document is generated from our Online Catalog. Please find the complete data in the user's documentation. Our General Terms of Use for Downloads are valid (<http://phoenixcontact.com/download>)



Control cabinet feed-through, M12, 4-pos., D-coded to RJ45 socket, socket entry: 180°, IP65/IP67

Your advantages

- ✓ Compact design
- ✓ 100 Mbps
- ✓ IP65/67
- ✓ UL



Key Commercial Data

Packing unit	1 pc
GTIN	 4 055626 166759
GTIN	4055626166759
Weight per Piece (excluding packing)	40.000 g
Custom tariff number	85366990
Country of origin	Germany

Technical data

Mechanical characteristics

Thread type	M12
Cable outlet	straight
Weight	33.6 g
Flammability rating according to UL 94	V0

Ambient conditions

Control cabinet feed-through - CUC-BH-M12D1PBK-S/R4BE - 1414398

Technical data

Ambient conditions

Ambient temperature (operation)	-25 °C ... 85 °C
---------------------------------	------------------

Material data

Contact material	Copper alloy
Housing material	PA
Mounting type	Rear mounting

Electrical characteristics

Number of positions	4
Nominal voltage U_N	48 V
Nominal current I_N	0.5 A
Transmission characteristics (category)	CAT5 (IEC 11801:2002)
GRP transmission properties	Ethernet CAT5 (IEC 11801:2002) CAT5 (IEC 11801:2002)
Transmission speed	100 Mbps
Rated current	1.75 A
Rated voltage (III/3)	72 V (DC)

Standards and Regulations

Flammability rating according to UL 94	V0
--	----

Environmental Product Compliance

REACH SVHC	Lead 7439-92-1
China RoHS	Environmentally Friendly Use Period = 50 years
	For details about hazardous substances go to tab "Downloads", Category "Manufacturer's declaration"

Drawings

Control cabinet feed-through - CUC-BH-M12D1PBK-S/R4BE - 1414398

Exploded view

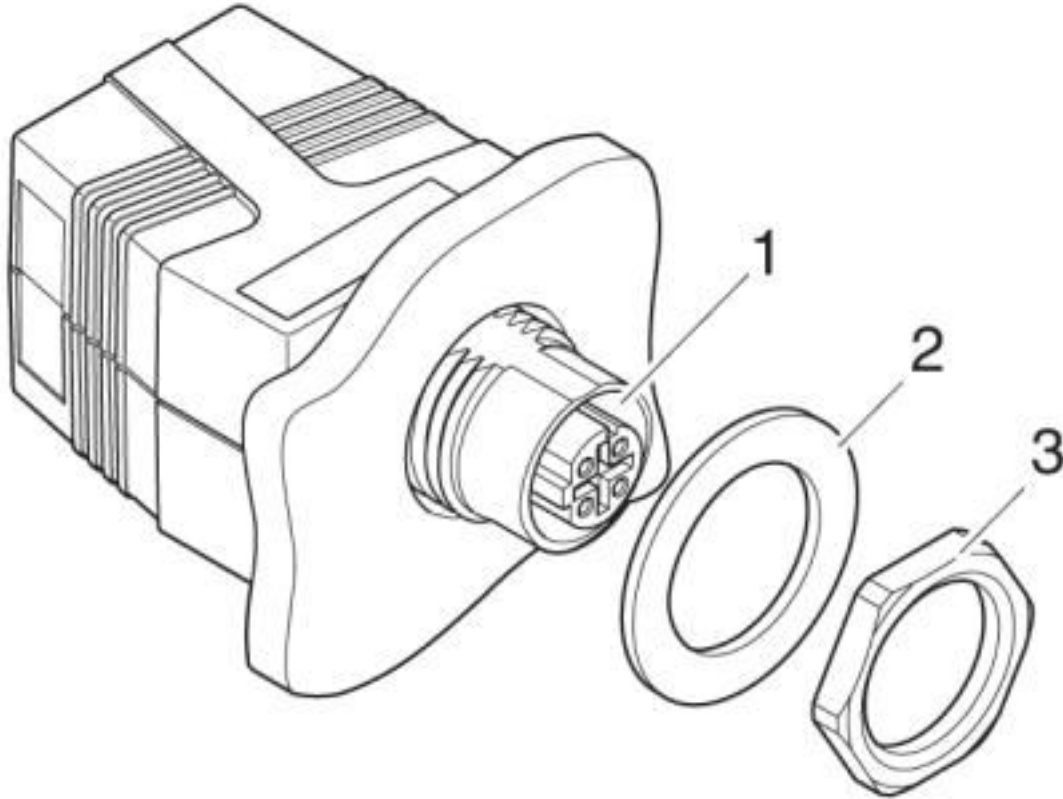

Exploded drawing

Dimensional drawing

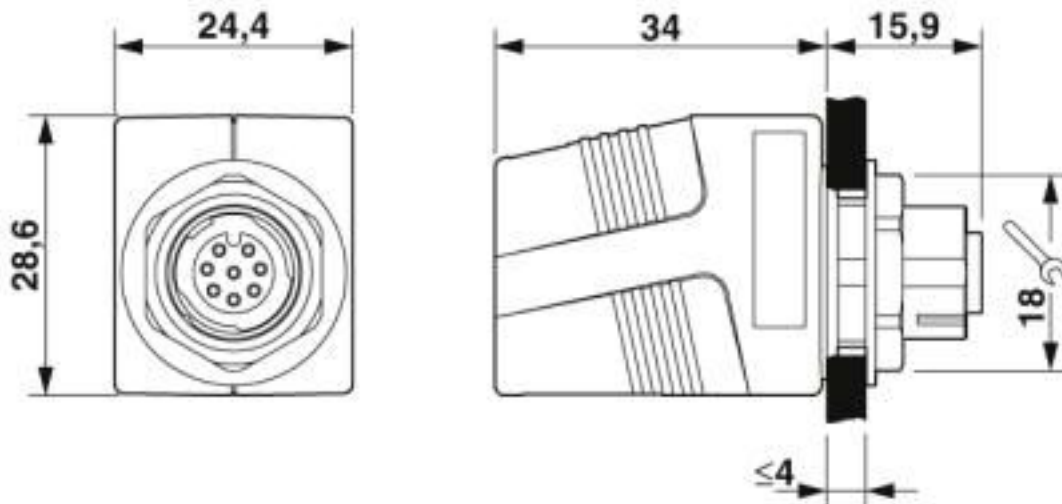

Control cabinet feed-through - CUC-BH-M12D1PBK-S/R4BE - 1414398

Dimensional drawing

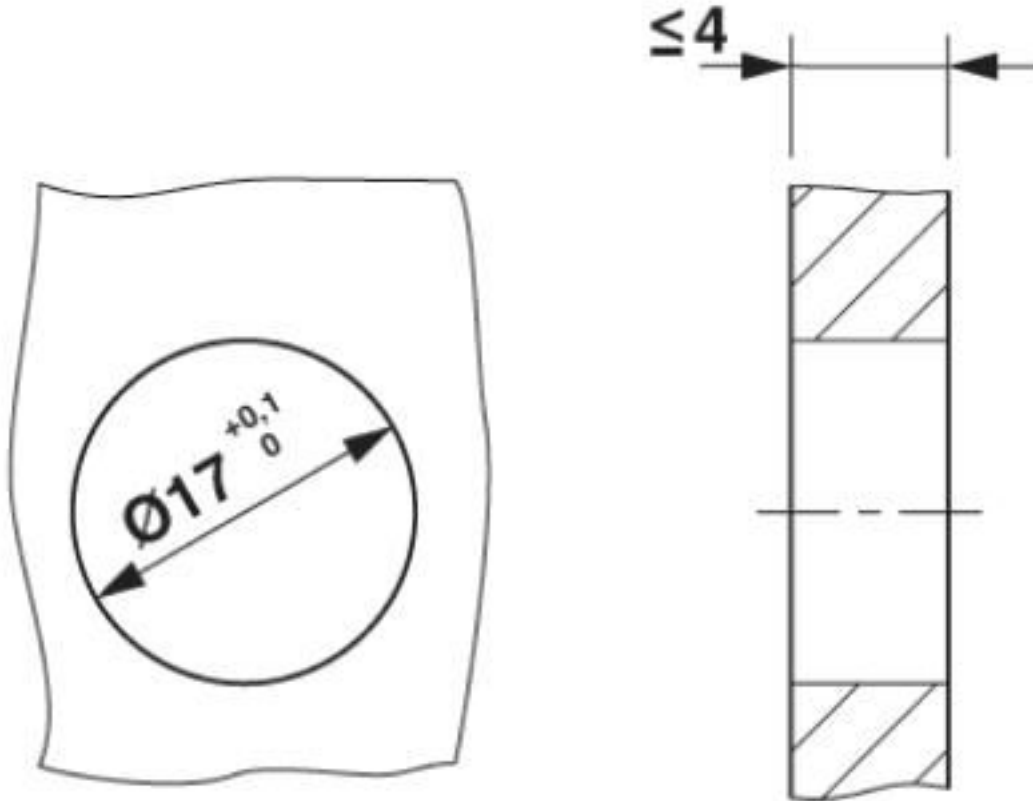

Mounting cutout

Control cabinet feed-through - CUC-BH-M12D1PBK-S/R4BE - 1414398

Circuit diagram

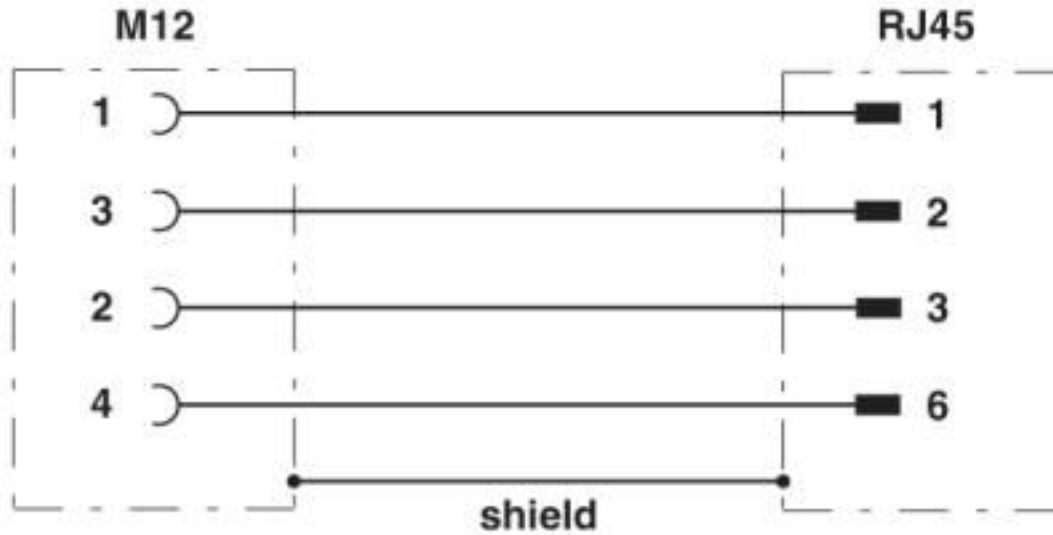

Circuit diagram

Classifications

eCl@ss

eCl@ss 10.0.1	27141134
eCl@ss 5.0	27141100
eCl@ss 5.1	27141100
eCl@ss 6.0	27141100
eCl@ss 7.0	27141134
eCl@ss 8.0	27141134
eCl@ss 9.0	27141134

ETIM

ETIM 5.0	EC001283
ETIM 6.0	EC001283
ETIM 7.0	EC001283

UNSPSC

UNSPSC 13.2	39121410
UNSPSC 18.0	39121410
UNSPSC 19.0	39121410
UNSPSC 20.0	39121410
UNSPSC 21.0	39121410

Control cabinet feed-through - CUC-BH-M12D1PBK-S/R4BE - 1414398

Approvals

Approvals

Approvals

UL Listed / cUL Listed / EAC / cULus Listed

Ex Approvals

Approval details

UL Listed		http://database.ul.com/cgi-bin/XYV/template/LISEXT/1FRAME/index.htm	E335024-20140306
Nominal voltage UN		60 V	
Nominal current IN		0.5 A	

cUL Listed		http://database.ul.com/cgi-bin/XYV/template/LISEXT/1FRAME/index.htm	E335024-20140306
Nominal voltage UN		60 V	
Nominal current IN		0.5 A	

EAC			B.01687
-----	--	--	---------

cULus Listed			
--------------	--	--	--