

Housing - HC-STA-B24-HHWD-1STM40-EL-AL - 1412766

Please be informed that the data shown in this PDF Document is generated from our Online Catalog. Please find the complete data in the user's documentation. Our General Terms of Use for Downloads are valid (<http://phoenixcontact.com/download>)



Sleeve housing B24, with double locking latch, material: Die-cast aluminum, salt water resistant, cable outlets: 1, lateral, height: 76 mm, cable gland: none, support sleeve: no, 1x M40, Standard

Your advantages

- good shielding in the event of electromagnetic interference

RoHS



Key Commercial Data

Packing unit	1 pc
GTIN	 4 055626 060323
GTIN	4055626060323
Weight per Piece (excluding packing)	300.000 g
Custom tariff number	85389099
Country of origin	China

Technical data

Dimensions

Height	76 mm
Width	44 mm
Length	120 mm

Ambient conditions

Degree of protection (IP)	IP66
	IP67
Degree of protection (NEMA)	4 (UL 50e)
	4X (UL 50e)

Housing - HC-STA-B24-HHWD-1STM40-EL-AL - 1412766

Technical data

Ambient conditions

	12 (UL 50e)
Ambient temperature (operation)	-40 °C ... 125 °C

General

Note	for contact inserts HC-B24, BB46, D64, DD108, HV10/16, M
Size	B24
Housing type	Sleeve housing
Color	gray aluminum
Locking type	with double locking latch
No. of cable outlets	1
Cable outlet	lateral
Screw connection	none
Type of the screw connection	1x M40
Housing material	Die-cast aluminum, salt water resistant
Housing surface material	uncoated
Material lock	PA

Environmental Product Compliance

China RoHS	Environmentally friendly use period: unlimited = EFUP-e
	No hazardous substances above threshold values

Drawings

Dimensional drawing

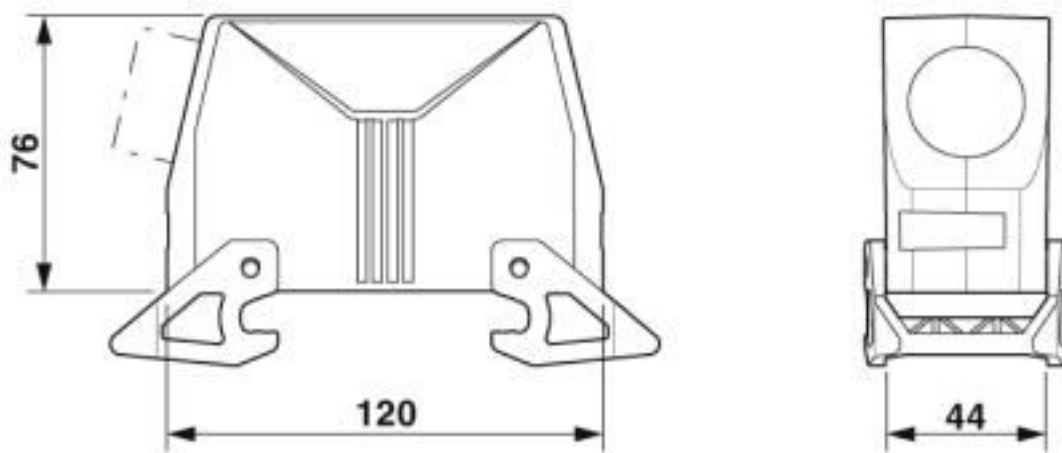

Dimensional drawing

Housing - HC-STA-B24-HHWD-1STM40-EL-AL - 1412766

Classifications

eCl@ss

eCl@ss 10.0.1	27440202
eCl@ss 5.1	27261200
eCl@ss 6.0	27261200
eCl@ss 7.0	27440202
eCl@ss 8.0	27440202
eCl@ss 9.0	27440202

ETIM

ETIM 5.0	EC000437
ETIM 6.0	EC000437
ETIM 7.0	EC000437

UNSPSC

UNSPSC 13.2	31261501
UNSPSC 18.0	31261501
UNSPSC 19.0	31261501
UNSPSC 20.0	31261501
UNSPSC 21.0	31261501

Approvals

Approvals

Approvals

UL Recognized / cUL Recognized / EAC / DNV GL / cULus Recognized

Ex Approvals

Approval details

UL Recognized		http://database.ul.com/cgi-bin/XYV/template/LISEXT/1FRAME/index.htm	E255026
---------------	--	---	---------

cUL Recognized		http://database.ul.com/cgi-bin/XYV/template/LISEXT/1FRAME/index.htm	E255026
----------------	--	---	---------

Housing - HC-STA-B24-HHWD-1STM40-EL-AL - 1412766

Approvals

EAC		RU C- DE.AI30.B.01102
-----	--	--------------------------

DNV GL		https://approvalfinder.dnvgl.com/	TAE000037S
--------	--	---	------------

cULus Recognized		
------------------	--	--

Accessories

Accessories

Full screw connection

Cable gland - G-INS-M40-M68N-NNES-S - 1411167



Cable gland, cable gland material: Nickel-plated brass, external cable diameter 19 mm ... 28 mm, shielding: no, connecting thread: M40 x 1.5, color: silver, with O-ring

Cable gland - G-INSEC-M40-M68N-NCRS-S - 1411192



Cable gland, cable gland material: Nickel-plated brass, external cable diameter 19 mm ... 27 mm, shielding: yes, connecting thread: M40 x 1.5, color: silver, with O-ring

Housing latches

Housing brackets - HC-STA-B10-24-DL-PLBK - 1412886



Double locking latch for B10 / B16 / B24 housing, HC-EVO...AL and HC-STA...AL

Housing - HC-STA-B24-HHWD-1STM40-EL-AL - 1412766

Accessories

Labeled device marker

Plastic label - US-EMLP (20X9) CUS - 0830085



Plastic label, can be ordered: By card, white, labeled according to customer specifications, mounting type: adhesive, lettering field size: 20 x 9 mm, Number of individual labels: 75

Protective cover

Protective covers - HC-B24-HCLFD-PR-BK - 1414633



Protective cover B24, for double locking latch, protective cover material: PA, height: 21.6 mm, seal: yes, diameter of retaining cord eyelet: 30 mm
