

Housing - HC-STA-B24-CHWD-1TTP29-ELC-AL - 1412745

Please be informed that the data shown in this PDF Document is generated from our Online Catalog. Please find the complete data in the user's documentation. Our General Terms of Use for Downloads are valid (<http://phoenixcontact.com/download>)



Coupling housings B24, with double locking latch, material: Die-cast aluminum, salt water resistant, cable outlets: 1, straight, height: 77 mm, cable gland: none, support sleeve: no, 1x Pg29, Standard

Your advantages

- good shielding in the event of electromagnetic interference

RoHS



Key Commercial Data

Packing unit	1 pc
GTIN	
GTIN	4055626058979
Weight per Piece (excluding packing)	300.000 g
Custom tariff number	85389099
Country of origin	China

Technical data

Dimensions

Height	77 mm
Width	44 mm
Length	120 mm

Ambient conditions

Degree of protection (IP)	IP66
	IP67
Degree of protection (NEMA)	4 (UL 50e)
	4X (UL 50e)

Housing - HC-STA-B24-CHWD-1TTP29-ELC-AL - 1412745

Technical data

Ambient conditions

	12 (UL 50e)
Ambient temperature (operation)	-40 °C ... 125 °C

General

Note	for contact inserts HC-B24, BB46, D64, DD108, HV10/16, M
Size	B24
Housing type	Coupling housings
Color	gray aluminum
Locking type	with double locking latch
No. of cable outlets	1
Cable outlet	straight
Screw connection	none
Type of the screw connection	1x Pg29
Housing material	Die-cast aluminum, salt water resistant
Housing surface material	uncoated
Seal material	NBR, conductive
Material lock	PA

Environmental Product Compliance

China RoHS	Environmentally Friendly Use Period = 50 years
	For details about hazardous substances go to tab "Downloads", Category "Manufacturer's declaration"

Drawings

Housing - HC-STA-B24-CHWD-1TTP29-ELC-AL - 1412745

Dimensional drawing

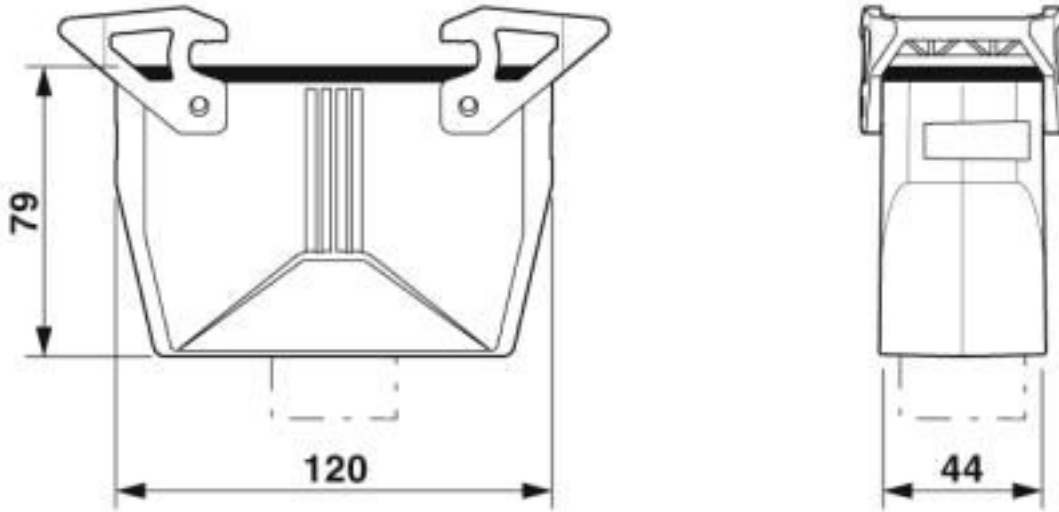

Dimensional drawing

Classifications

eCl@ss

eCl@ss 10.0.1	27440202
eCl@ss 5.1	27261200
eCl@ss 6.0	27261200
eCl@ss 7.0	27440202
eCl@ss 8.0	27440202
eCl@ss 9.0	27440202

ETIM

ETIM 5.0	EC000437
ETIM 6.0	EC000437
ETIM 7.0	EC000437

UNSPSC

UNSPSC 13.2	31261501
UNSPSC 18.0	31261501
UNSPSC 19.0	31261501
UNSPSC 20.0	31261501
UNSPSC 21.0	31261501

Housing - HC-STA-B24-CHWD-1TTP29-ELC-AL - 1412745

Approvals

Approvals

Approvals

UL Recognized / cUL Recognized / EAC / DNV GL / cULus Recognized

Ex Approvals

Approval details

UL Recognized		http://database.ul.com/cgi-bin/XYV/template/LISEXT/1FRAME/index.htm	E255026
cUL Recognized		http://database.ul.com/cgi-bin/XYV/template/LISEXT/1FRAME/index.htm	E255026
EAC			RU C- DE.AI30.B.01102
DNV GL		https://approvalfinder.dnvgl.com/	TAE000037S
cULus Recognized			

Accessories

Accessories

Full screw connection

Housing - HC-STA-B24-CHWD-1TTP29-ELC-AL - 1412745

Accessories

Cable gland - G-INS-PG29-M68N-NNES-S - 1411176



Cable gland, cable gland material: Nickel-plated brass, external cable diameter 18 mm ... 25 mm, shielding: no, connecting thread: Pg29, color: silver, with O-ring

Cable gland - G-INSEC-PG29-M68N-NNES-S - 1411201



Cable gland, cable gland material: Nickel-plated brass, external cable diameter 18 mm ... 25 mm, shielding: yes, connecting thread: Pg29, color: silver, with O-ring

Housing latches

Replacement part - HC-STA-B24-SL-PLBK - 1412885



Single locking latch for B24 housing, HC-EVO...AL and HC-STA...AL

Labeled device marker

Plastic label - US-EMLP (20X9) CUS - 0830085



Plastic label, can be ordered: By card, white, labeled according to customer specifications, mounting type: adhesive, lettering field size: 20 x 9 mm, Number of individual labels: 75

Protective cover

Housing - HC-STA-B24-CHWD-1TTP29-ELC-AL - 1412745

Accessories

Protective covers - HC-B24-BCSFD-P-BK - 1414630



Protective cover B24, for double locking latch, protective cover material: PA, height: 18.5 mm, seal: no, diameter of retaining cord eyelet: 40 mm

Seal

Profile gasket - HC-B24-SP-CBK - 1411482



Profile gasket for HEAVYCON EVO supporting base element type B24, conductive