

# Housing - HC-STA-B10-HLWD-1STP21-EL-AL - 1412636

Please be informed that the data shown in this PDF Document is generated from our Online Catalog. Please find the complete data in the user's documentation. Our General Terms of Use for Downloads are valid (<http://phoenixcontact.com/download>)



Sleeve housing B10, with double locking latch, material: Die-cast aluminum, salt water resistant, cable outlets: 1, lateral, height: 57 mm, cable gland: none, support sleeve: no, 1x Pg21, Standard

## Your advantages

- good shielding in the event of electromagnetic interference



## Key Commercial Data

Packing unit	1 pc
GTIN	
GTIN	4055626059624
Custom tariff number	85389099
Country of origin	China

## Technical data

### Dimensions

Height	57 mm
Width	44 mm
Length	73 mm

### Ambient conditions

Degree of protection (IP)	IP66
	IP67
Degree of protection (NEMA)	4 (UL 50e)
	4X (UL 50e)
	12 (UL 50e)

# Housing - HC-STA-B10-HLWD-1STP21-EL-AL - 1412636

## Technical data

### Ambient conditions

Ambient temperature (operation)	-40 °C ... 125 °C
---------------------------------	-------------------

### General

Note	For contact inserts HC-B10, BB18, DD42, M, K8/24
Size	B10
Housing type	Sleeve housing
Color	gray aluminum
Locking type	with double locking latch
No. of cable outlets	1
Cable outlet	lateral
Screw connection	none
Type of the screw connection	1x Pg21
Housing material	Die-cast aluminum, salt water resistant
Housing surface material	uncoated
Material lock	PA

### Environmental Product Compliance

China RoHS	Environmentally Friendly Use Period = 50 years
	For details about hazardous substances go to tab "Downloads", Category "Manufacturer's declaration"

## Drawings

Dimensional drawing

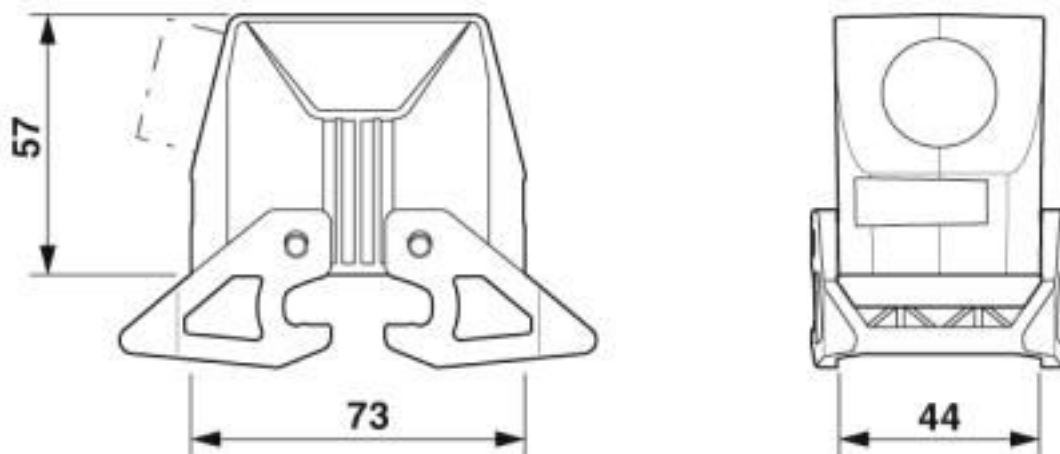

Dimensional drawing

# Housing - HC-STA-B10-HLWD-1STP21-EL-AL - 1412636

## Classifications

### eCl@ss

eCl@ss 10.0.1	27440202
eCl@ss 5.1	27261200
eCl@ss 6.0	27261200
eCl@ss 7.0	27440202
eCl@ss 8.0	27440202
eCl@ss 9.0	27440202

### ETIM

ETIM 5.0	EC000437
ETIM 6.0	EC000437
ETIM 7.0	EC000437

### UNSPSC

UNSPSC 13.2	31261501
UNSPSC 18.0	31261501
UNSPSC 19.0	31261501
UNSPSC 20.0	31261501
UNSPSC 21.0	31261501

## Approvals

### Approvals

#### Approvals

UL Recognized / cUL Recognized / EAC / DNV GL / cULus Recognized

#### Ex Approvals

### Approval details

UL Recognized		<a href="http://database.ul.com/cgi-bin/XYV/template/LISEXT/1FRAME/index.htm">http://database.ul.com/cgi-bin/XYV/template/LISEXT/1FRAME/index.htm</a>	E255026
---------------	--	---	---------

cUL Recognized		<a href="http://database.ul.com/cgi-bin/XYV/template/LISEXT/1FRAME/index.htm">http://database.ul.com/cgi-bin/XYV/template/LISEXT/1FRAME/index.htm</a>	E255026
----------------	--	---	---------

## Housing - HC-STA-B10-HLWD-1STP21-EL-AL - 1412636

### Approvals

EAC		RU C- DE.AI30.B.01102
-----	--	--------------------------

DNV GL		<a href="https://approvalfinder.dnvgl.com/">https://approvalfinder.dnvgl.com/</a>	TAE000037S
--------	--	---	------------

cULus Recognized		
------------------	--	--

### Accessories

#### Accessories

##### Full screw connection

Cable gland - G-INS-PG21-M68N-NNES-S - 1411175



Cable gland, cable gland material: Nickel-plated brass, external cable diameter 13 mm ... 18 mm, shielding: no, connecting thread: Pg21, color: silver, with O-ring

Cable gland - G-INSEC-PG21-M68N-NNES-S - 1411200



Cable gland, cable gland material: Nickel-plated brass, external cable diameter 13 mm ... 18 mm, shielding: yes, connecting thread: Pg21, color: silver, with O-ring

### Housing latches

Housing brackets - HC-STA-B10-24-DL-PLBK - 1412886



Double locking latch for B10 / B16 / B24 housing, HC-EVO...AL and HC-STA...AL

## Housing - HC-STA-B10-HLWD-1STP21-EL-AL - 1412636

### Accessories

---

#### Labeled device marker

Plastic label - US-EMLP (20X9) CUS - 0830085



Plastic label, can be ordered: By card, white, labeled according to customer specifications, mounting type: adhesive, lettering field size: 20 x 9 mm, Number of individual labels: 75

---

#### Protective cover

Protective covers - HC-B10-BCSFD-P-BK - 1414628



Protective cover B10, for double locking latch, protective cover material: PA, height: 18.5 mm, seal: no, diameter of retaining cord eyelet: 40 mm

---