

Seal - HC-MOT-AFL-FL-DI - 1409257

Please be informed that the data shown in this PDF Document is generated from our Online Catalog. Please find the complete data in the user's documentation. Our General Terms of Use for Downloads are valid (<http://phoenixcontact.com/download>)

Flat gasket for flange



Key Commercial Data

Packing unit	1 pc
Minimum order quantity	10 pc
GTIN	 4 046356 619479
GTIN	4046356619479
Custom tariff number	39269097
Country of origin	Germany

Technical data

Material data

Seal material	EPDM
---------------	------

Standards and Regulations

Safety note	WARNING: The connectors may not be plugged in or disconnected under load. Ignoring the warning or improper use may damage persons and/or property.
	• WARNING: Commission properly functioning products only. The products must be regularly inspected for damage. Decommission defective products immediately. Replace damaged products. Repairs are not possible.
	• WARNING: Only electrically qualified personnel may install and operate the product. They must observe the following safety notes. The qualified personnel must be familiar with the basics of electrical engineering. They must be able to recognize and prevent danger. The relevant symbol on the packaging indicates that only personnel familiar with electrical engineering are allowed to install and operate the product.

Seal - HC-MOT-AFL-FL-DI - 1409257

Technical data

Standards and Regulations

	<ul style="list-style-type: none"> The products are suitable for applications in plant, controller, and electrical device engineering.
	<ul style="list-style-type: none"> When operating the connectors in outdoor applications, they must be separately protected against environmental influences.
	<ul style="list-style-type: none"> Assembled products may not be manipulated or improperly opened.
	<ul style="list-style-type: none"> Only use mating connectors that are specified in the technical data of the standards listed (e.g. the ones listed in the product accessories online at phoenixcontact.com/products).
	<ul style="list-style-type: none"> When using the product in direct connection with third-party manufacturers, the user is responsible.
	<ul style="list-style-type: none"> For operating voltages > 50 V AC, conductive connector housings must be grounded
	<ul style="list-style-type: none"> Ensure that the protective or functional ground has been properly connected.
	<ul style="list-style-type: none"> VDE 0100/1.97 § 411.1.3.2 and DIN EN 60 204/11.98 § 14.1.3 are applicable when combining several circuits in a cable and/or connector
	<ul style="list-style-type: none"> Observe the corresponding technical data. You will find information: <ul style="list-style-type: none"> On the product On the packing label In the supplied documentation Online at phoenixcontact.com/products under the product
	<ul style="list-style-type: none"> Only use tools recommended by Phoenix Contact
	<ul style="list-style-type: none"> The installation notes/Design In documents online on the download page at phoenixcontact.com/products must be observed for this product.
	<ul style="list-style-type: none"> Use a protective cap to protect connectors that are not in use. The suitable accessories are available online in the accessory section of the product at phoenixcontact.com/products
	<ul style="list-style-type: none"> Operate the connector only when it is fully plugged in.
	<ul style="list-style-type: none"> Ensure that when laying the cable, the tensile load on the connectors does not exceed the upper limit specified in the standards.
	<ul style="list-style-type: none"> Observe the minimum bending radius of the cable. Lay the cable without twisting it.

Environmental Product Compliance

China RoHS	Environmentally friendly use period: unlimited = EFUP-e
	No hazardous substances above threshold values

Drawings

Seal - HC-MOT-AFL-FL-DI - 1409257

Dimensional drawing

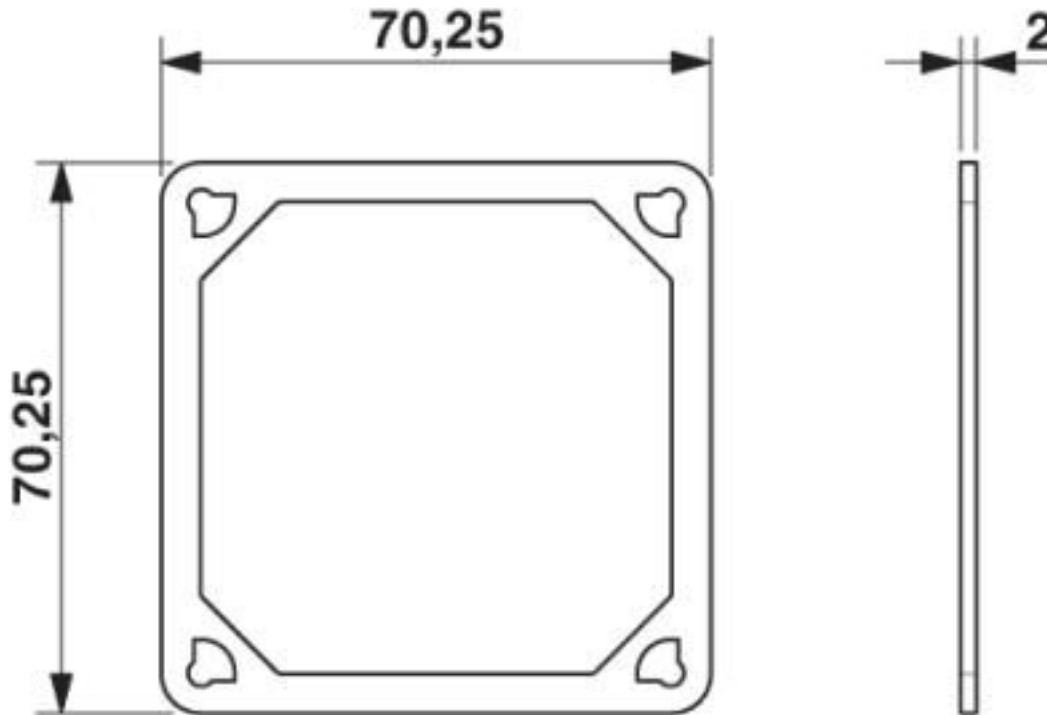

Dimensional drawing

Classifications

eCl@ss

eCl@ss 10.0.1	27430319
eCl@ss 4.0	27140800
eCl@ss 4.1	27140800
eCl@ss 5.0	27143400
eCl@ss 5.1	27143400
eCl@ss 6.0	27143400
eCl@ss 7.0	27439218
eCl@ss 8.0	27439218
eCl@ss 9.0	27430319

ETIM

ETIM 4.0	EC002498
ETIM 5.0	EC001181
ETIM 6.0	EC001181

Seal - HC-MOT-AFL-FL-DI - 1409257

Classifications

ETIM

ETIM 7.0	EC001181
----------	----------

UNSPSC

UNSPSC 6.01	30211817
UNSPSC 7.0901	39121416
UNSPSC 11	43172601
UNSPSC 12.01	39121522
UNSPSC 13.2	39131608
UNSPSC 18.0	39131608
UNSPSC 19.0	39131608
UNSPSC 20.0	39131608
UNSPSC 21.0	39131608