

## Mounting frame - SI-M1A-GL - 1407592

Please be informed that the data shown in this PDF Document is generated from our Online Catalog. Please find the complete data in the user's documentation. Our General Terms of Use for Downloads are valid (<http://phoenixcontact.com/download>)



Mounting frame for one front plate/socket, plastic frame: black, plastic cover: gray, closed with 3 mm two-way key bit and rotary knob, included.

RoHS

### Key Commercial Data

Packing unit	1 pc
GTIN	 4 046356 776042
GTIN	4046356776042
Weight per Piece (excluding packing)	120.000 g
Custom tariff number	85389099
Country of origin	Germany

### Technical data

#### Dimensions

Width	66 mm
Length	127 mm
Length of the assembly cutout	91 mm
Width of the assembly cutout	52 mm

#### Ambient conditions

Ambient temperature (operation)	-30 °C ... 70 °C
---------------------------------	------------------

#### General

Note	with enclosed rotary knob
Type	For 1 front plate
Color	white

## Mounting frame - SI-M1A-GL - 1407592

### Technical data

#### General

Housing material	PBT
Flammability rating according to UL 94	V0
Assembly instructions	Suitable for panel thicknesses 1 mm ... 5 mm

#### Standards and Regulations

Flammability rating according to UL 94	V0
--	----

#### Environmental Product Compliance

REACH SVHC	Lead 7439-92-1
China RoHS	Environmentally Friendly Use Period = 50 years
	For details about hazardous substances go to tab "Downloads", Category "Manufacturer's declaration"

### Drawings

# Mounting frame - SI-M1A-GL - 1407592

Dimensional drawing

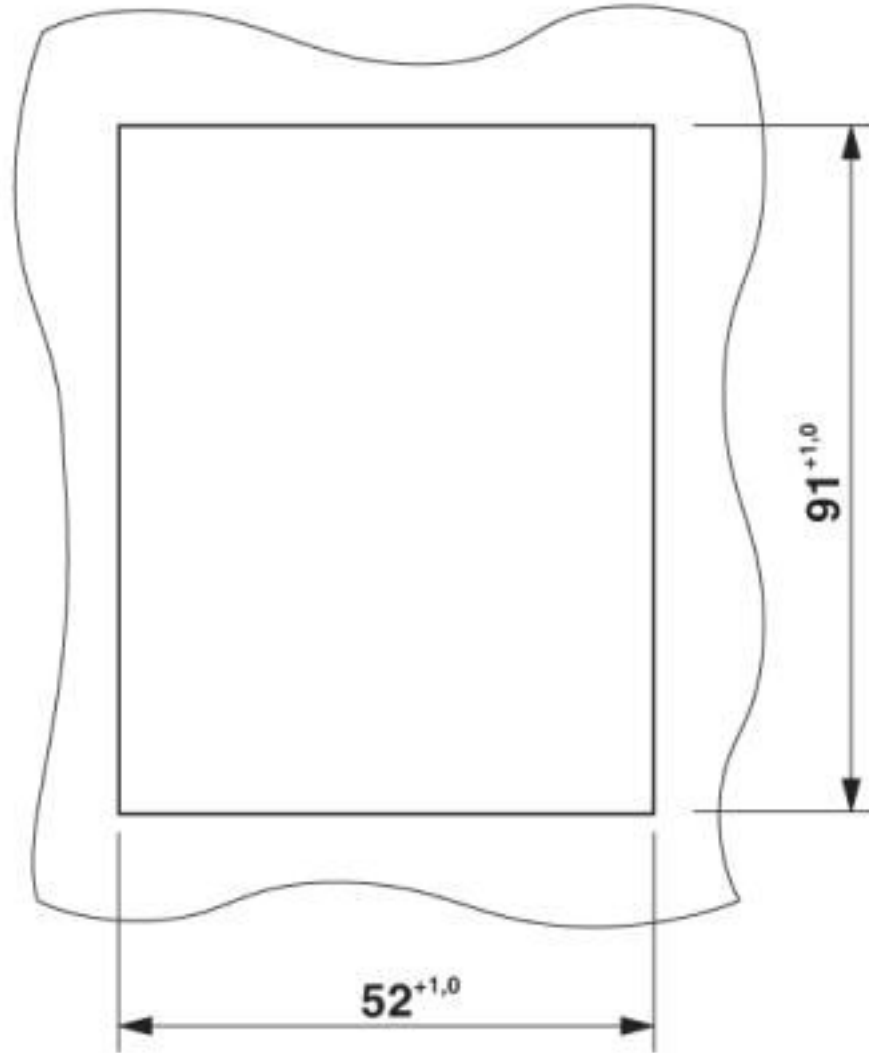

Mounting cutout

# Mounting frame - SI-M1A-GL - 1407592

Dimensional drawing

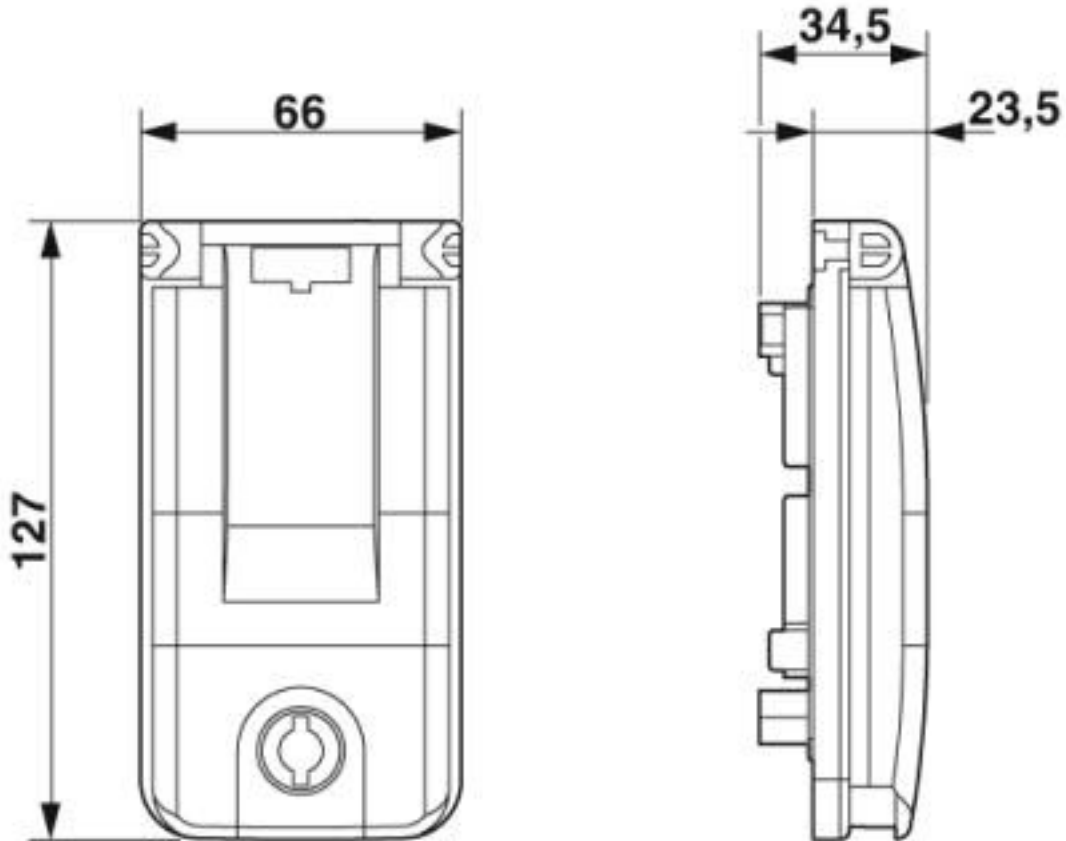

Dimensional drawing

## Classifications

eCl@ss

eCl@ss 10.0.1	27182806
eCl@ss 4.0	27141200
eCl@ss 4.1	27141200
eCl@ss 5.0	27144000
eCl@ss 5.1	27144000
eCl@ss 6.0	27144000
eCl@ss 7.0	27144001
eCl@ss 8.0	27144001
eCl@ss 9.0	27189217

# Mounting frame - SI-M1A-GL - 1407592

## Classifications

### ETIM

ETIM 3.0	EC000441
ETIM 4.0	EC002625
ETIM 5.0	EC002625
ETIM 6.0	EC000456
ETIM 7.0	EC000456

### UNSPSC

UNSPSC 6.01	30211808
UNSPSC 7.0901	39121408
UNSPSC 11	39121408
UNSPSC 12.01	39121408
UNSPSC 13.2	39121408
UNSPSC 18.0	39121302
UNSPSC 19.0	39121302
UNSPSC 20.0	39121302
UNSPSC 21.0	39121302

## Approvals

### Approvals

---

#### Approvals

UL Recognized / cUL Recognized / EAC / cULus Recognized

---

#### Ex Approvals

---

### Approval details

UL Recognized		<a href="http://database.ul.com/cgi-bin/XYV/template/LISEXT/1FRAME/index.htm">http://database.ul.com/cgi-bin/XYV/template/LISEXT/1FRAME/index.htm</a>	E255026
---------------	--	---	---------

cUL Recognized		<a href="http://database.ul.com/cgi-bin/XYV/template/LISEXT/1FRAME/index.htm">http://database.ul.com/cgi-bin/XYV/template/LISEXT/1FRAME/index.htm</a>	E255026
----------------	--	---	---------

# Mounting frame - SI-M1A-GL - 1407592

## Approvals

EAC		RU C- DE.A*30.B.01102
-----	---	--------------------------

cULus Recognized	
------------------	---

## Accessories

### Accessories

#### Data front plate

Front plate - VS-SI-FP-2RJ-MOD - 1656631



Front plate, plastic with shroud, for 2x RJ with modular system (Keystone)

Front plate - VS-SI-FP-2DSUB9 - 1656563



Data front plate, plastic, for 2 x 9-pos. D-SUB, item 1656961 may be required for mounting D-SUB inserts

Front plate - VS-SI-FP-DSUB9-DSUB15 - 1656576



Data front plate, plastic, for 1 x 15-pos. D-SUB and 1 x 15-pos. D-SUB, item 1656961 may be required for mounting D-SUB inserts

## Mounting frame - SI-M1A-GL - 1407592

### Accessories

Front plate - VS-SI-FP-DSUB9-DSUB25 - 1656589



Data front plate, plastic, for 1 x 9-pos. D-SUB and 1 x 25-pos. D-SUB, item 1656961 may be required for mounting D-SUB inserts

---

Front plate - VS-SI-FP-2DSUB15 - 1656592



Data front plate, plastic, for 2 x 15-pos. D-SUB, item 1656961 may be required for mounting D-SUB inserts

---

Front plate - VS-SI-FP-DSUB15-DSUB25 - 1656602



Data front plate, plastic, for 1 x 15-pos. D-SUB and 1 x 25-pos. D-SUB, item 1656961 may be required for mounting D-SUB inserts

---

Front plate - VS-SI-FP-2DSUB25 - 1656615



Data front plate, plastic, for 2x D-SUB 25, item 1656961 may be required for mounting D-SUB inserts

---

Front plate - VS-SI-FP-BP - 1656657



Front plate, degree of protection: IP20, material: PBT, color: gray

---

## Mounting frame - SI-M1A-GL - 1407592

### Accessories

Front plate - VS-SI-FP-2F - 1658532



Front plate, plastic, with two Freenet slots