

DIN rail mounting frame - HC-CIF-2B6-HFFD-WH-AL - 1404215

Please be informed that the data shown in this PDF Document is generated from our Online Catalog. Please find the complete data in the user's documentation. Our General Terms of Use for Downloads are valid (<http://phoenixcontact.com/download>)



HEAVYCON DIN rail mounting frame, upper part for double locking latch, for HC-CIF...BFWD.. lower parts with double locking latch or for HC-CIF...BFFD.. lower parts, for two type B6 contact inserts, with M4 screws with 3 mm Allen screw head, for NS35/7,5 DIN rails

Your advantages

- ✓ Sturdy metal version
- ✓ Open base, pre-assembled cable harnesses can be used
- ✓ Standardized design; both PE sheets for inserts are connected conductively
- ✓ Safe capacitive PE even when connected slightly askew



Key Commercial Data

Packing unit	1 pc
GTIN	 4 046356 681872
GTIN	4046356681872
Weight per Piece (excluding packing)	120.000 g
Custom tariff number	85389099
Country of origin	Poland

Technical data

Dimensions

Length	150.2 mm
Width	56 mm
Height	49 mm

Ambient conditions

Ambient temperature (operation)	-40 °C ... 125 °C
---------------------------------	-------------------

DIN rail mounting frame - HC-CIF-2B6-HFFD-WH-AL - 1404215

Technical data

General

Size	For 2xB6
Material	Cast aluminum, uncoated
Connection	For screw locking: M4, 3 mm Allen screw, 2 Nm tightening torque

Environmental Product Compliance

China RoHS	Environmentally friendly use period: unlimited = EFUP-e
	No hazardous substances above threshold values

Drawings

Dimensional drawing

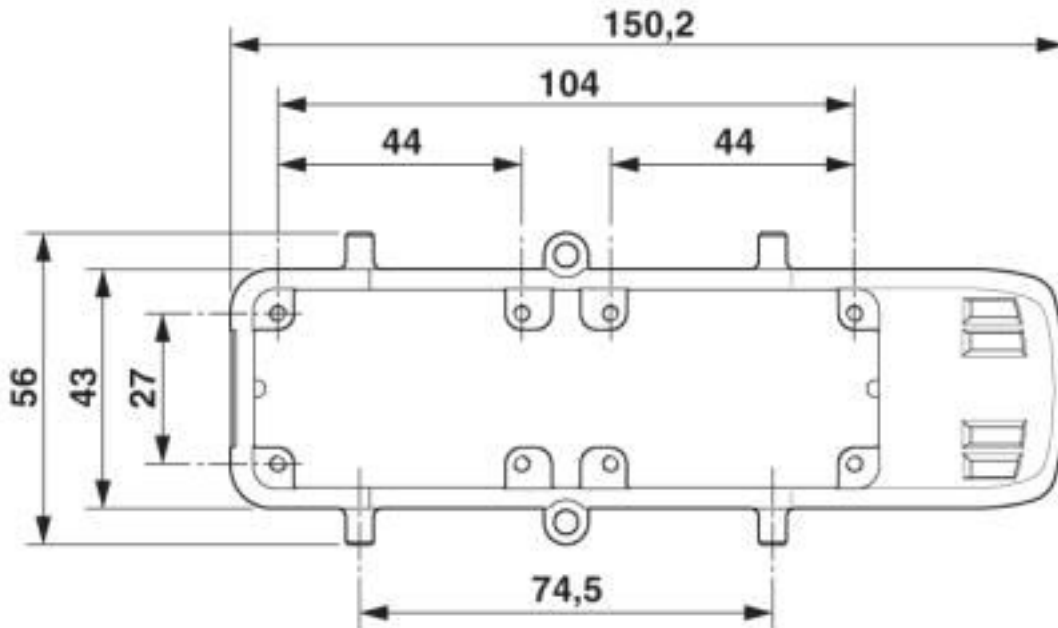

Dimensional drawing top view

DIN rail mounting frame - HC-CIF-2B6-HFFD-WH-AL - 1404215

Dimensional drawing

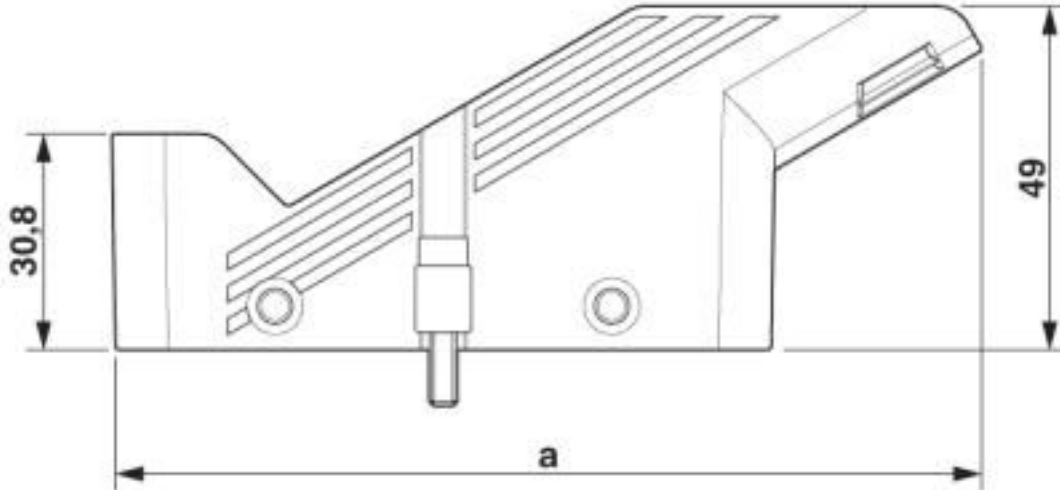

Dimensional drawing

Classifications

eCl@ss

eCl@ss 10.0.1	27440210
eCl@ss 4.0	27140800
eCl@ss 4.1	27140800
eCl@ss 5.0	27143400
eCl@ss 5.1	27143400
eCl@ss 6.0	27261200
eCl@ss 7.0	27440206
eCl@ss 8.0	27440206
eCl@ss 9.0	27440210

ETIM

ETIM 3.0	EC002310
ETIM 4.0	EC002310
ETIM 5.0	EC002310
ETIM 6.0	EC002310
ETIM 7.0	EC002310

UNSPSC

UNSPSC 6.01	43172601
UNSPSC 7.0901	39121416

DIN rail mounting frame - HC-CIF-2B6-HFFD-WH-AL - 1404215

Classifications

UNSPSC

UNSPSC 11	43172601
UNSPSC 12.01	39121408
UNSPSC 13.2	39121421
UNSPSC 18.0	39121421
UNSPSC 19.0	39121421
UNSPSC 20.0	39121421
UNSPSC 21.0	39121421

Approvals

Approvals

Approvals

EAC

Ex Approvals

Approval details

EAC		RU C- DE.AI30.B.01102
-----	--	--------------------------

Accessories

Accessories

Device marking

Plastic label - US-EMLP (20X9) SR - 0828884



Plastic label, Card, silver, unlabeled, can be labeled with: BLUEMARK ID COLOR, BLUEMARK ID, THERMOMARK PRIME, THERMOMARK CARD 2.0, THERMOMARK CARD, mounting type: adhesive, lettering field size: 20 x 9 mm, Number of individual labels: 75

Additional products

DIN rail mounting frame - HC-CIF-2B6-HFFD-WH-AL - 1404215

Accessories

DIN rail mounting frame - HC-CIF-2B6-BFFD-FH-AL - 1404214



HEAVYCON DIN rail mounting frame, lower part for double locking latch, for housing with double locking latch or HC-CIF..HFFD.., for two type B6 contact inserts, for NS35/7,5 DIN rails