

## Philips screwdriver - SF-PZSL 1-80 S-VDE - 1212699

Please be informed that the data shown in this PDF Document is generated from our Online Catalog. Please find the complete data in the user's documentation. Our General Terms of Use for Downloads are valid (<http://phoenixcontact.com/download>)



Screwdriver, Plus-Minus PZH slot, VDE-isolated, size: PZ 1 x 80, two component handle, with non-slip grip

### Your advantages

- VDE approval
- Screwdrivers for Phillips screws with Pozidriv and Phillips Recess screw head

### Key Commercial Data

|                                      |   |
|--------------------------------------|---|
| Packing unit                         | 1 pc  |
| GTIN                                 | <br>4 046356 716628 |
| GTIN                                 | 4046356716628   |
| Weight per Piece (excluding packing) | 70.000 g  |
| Custom tariff number                 | 82054000  |
| Country of origin                    | Czech Republic  |

### Technical data

#### Dimensions

|              |        |
|--------------|--------|
| Length (b)   | 178 mm |
| Width (a)    | 33 mm  |
| Blade width  | 3 mm   |
| Blade height | 80 mm  |
| Wrench size  | 0 mm   |

#### General

|          |                    |
|----------|--------------------|
| Type     | Phillips           |
| Material | alloyed tool steel |

### Environmental Product Compliance

# Philips screwdriver - SF-PZSL 1-80 S-VDE - 1212699

## Technical data

### Environmental Product Compliance

|                           |   |
|---------------------------|---|
| California Proposition 65 | Further information on California's prop. 65 is available under "Downloads" in the manufacturer's declaration |
|---------------------------|---|

## Drawings

Pictogram



## Philips screwdriver - SF-PZSL 1-80 S-VDE - 1212699

Dimensional drawing

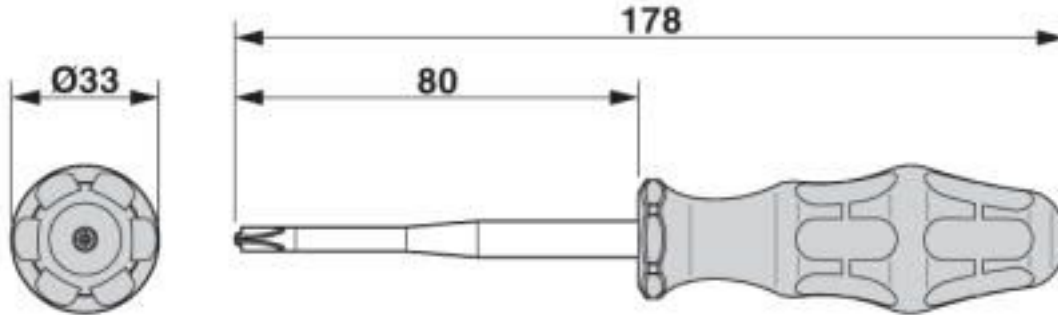

### Classifications

eCl@ss

|               |          |
|---------------|----------|
| eCl@ss 10.0.1 | 21040406 |
| eCl@ss 4.0    | 21040400 |
| eCl@ss 4.1    | 21040400 |
| eCl@ss 5.0    | 21040400 |
| eCl@ss 5.1    | 21040400 |
| eCl@ss 6.0    | 21040400 |
| eCl@ss 7.0    | 21040406 |
| eCl@ss 8.0    | 21040406 |
| eCl@ss 9.0    | 21040406 |

ETIM

|          |          |
|----------|----------|
| ETIM 3.0 | EC000158 |
| ETIM 4.0 | EC000144 |
| ETIM 5.0 | EC000144 |
| ETIM 6.0 | EC000144 |
| ETIM 7.0 | EC000144 |

UNSPSC

|               |          |
|---------------|----------|
| UNSPSC 6.01   | 27111701 |
| UNSPSC 7.0901 | 27111701 |
| UNSPSC 11     | 27111701 |
| UNSPSC 12.01  | 27111701 |
| UNSPSC 13.2   | 27111701 |
| UNSPSC 18.0   | 27111701 |
| UNSPSC 19.0   | 27111701 |
| UNSPSC 20.0   | 27111701 |
| UNSPSC 21.0   | 27111701 |

# Philips screwdriver - SF-PZSL 1-80 S-VDE - 1212699

## Approvals

### Approvals

---

#### Approvals

VDE Zeichengenehmigung / EAC

---

#### Ex Approvals

---

### Approval details

|                        |   |   |          |
|------------------------|---|---|----------|
| VDE Zeichengenehmigung |  | <a href="http://www2.vde.com/de/Institut/Online-Service/VDE-gepruefteProdukte/Seiten/Online-Suche.aspx">http://www2.vde.com/de/Institut/Online-Service/VDE-gepruefteProdukte/Seiten/Online-Suche.aspx</a> | 40032921 |
|------------------------|---|---|----------|

|     |  |  |                          |
|-----|--|--|--------------------------|
| EAC |  |  | RU C-<br>DE.AI30.B.01750 |
|-----|--|--|--------------------------|

---