

## Philips screwdriver - SF-PZ 2-100 S-VDE - 1212696

Please be informed that the data shown in this PDF Document is generated from our Online Catalog. Please find the complete data in the user's documentation. Our General Terms of Use for Downloads are valid (<http://phoenixcontact.com/download>)



Screwdriver, crosshead PZ (lasered), insulated, size: PZ 2 x 100, 2-component handle, with non-slip grip

### Your advantages

- VDE approval
- Screwdrivers for Phillips screws with Pozidriv and Phillips Recess screw head

### Key Commercial Data

Packing unit	1 pc
GTIN	 4 046356 716598
GTIN	4046356716598
Weight per Piece (excluding packing)	90.000 g
Custom tariff number	82054000
Country of origin	Czech Republic

### Technical data

#### Dimensions

Length (b)	205 mm
Width (a)	37 mm
Blade width	6 mm
Blade height	100 mm
Wrench size	0 mm

#### General

Type	Phillips
Material	alloyed tool steel

### Environmental Product Compliance

# Philips screwdriver - SF-PZ 2-100 S-VDE - 1212696

## Technical data

### Environmental Product Compliance

California Proposition 65	Further information on California's prop. 65 is available under "Downloads" in the manufacturer's declaration
---------------------------	---

## Drawings

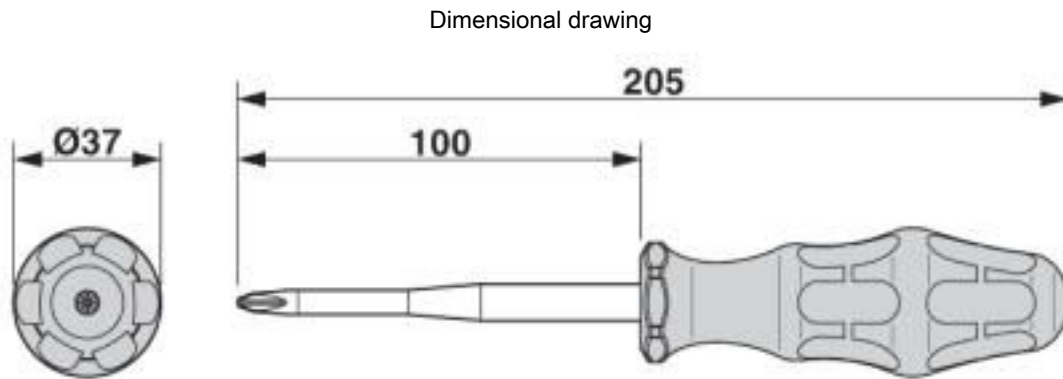

# Philips screwdriver - SF-PZ 2-100 S-VDE - 1212696

Pictogram



## Classifications

eCl@ss

eCl@ss 10.0.1	21040406
eCl@ss 4.0	21040400
eCl@ss 4.1	21040400
eCl@ss 5.0	21040400
eCl@ss 5.1	21040400
eCl@ss 6.0	21040400
eCl@ss 7.0	21040406

# Philips screwdriver - SF-PZ 2-100 S-VDE - 1212696

## Classifications

### eCl@ss

eCl@ss 8.0	21040406
eCl@ss 9.0	21040406

### ETIM

ETIM 3.0	EC000158
ETIM 4.0	EC000144
ETIM 5.0	EC000144
ETIM 6.0	EC000144
ETIM 7.0	EC000144

### UNSPSC

UNSPSC 6.01	27111701
UNSPSC 7.0901	27111701
UNSPSC 11	27111701
UNSPSC 12.01	27111701
UNSPSC 13.2	27111701
UNSPSC 18.0	27111701
UNSPSC 19.0	27111701
UNSPSC 20.0	27111701
UNSPSC 21.0	27111701

## Approvals

### Approvals

---

#### Approvals

VDE Zeichengenehmigung / EAC

---

#### Ex Approvals

---

### Approval details

VDE Zeichengenehmigung		<a href="http://www2.vde.com/de/Institut/Online-Service/VDE-gepruefteProdukte/Seiten/Online-Suche.aspx">http://www2.vde.com/de/Institut/Online-Service/VDE-gepruefteProdukte/Seiten/Online-Suche.aspx</a>	40032921
------------------------	--	---	----------

# Philips screwdriver - SF-PZ 2-100 S-VDE - 1212696

## Approvals

EAC



RU C-  
DE.AI30.B.01750