

Philips screwdriver - SF-PH 2-100 S-VDE - 1212694

Please be informed that the data shown in this PDF Document is generated from our Online Catalog. Please find the complete data in the user's documentation. Our General Terms of Use for Downloads are valid (<http://phoenixcontact.com/download>)



Screwdriver, crosshead PH (lasered), insulated, size: PH 2 x 100, 2-component handle, with non-slip grip

Your advantages

- Screwdrivers for Phillips screws with Pozidriv and Phillips Recess screw head

Key Commercial Data

Packing unit	1 pc
GTIN	 4 046356 716574
GTIN	4046356716574
Weight per Piece (excluding packing)	100.000 g
Custom tariff number	82054000
Country of origin	Czech Republic

Technical data

Dimensions

Length (b)	105 mm
Width (a)	37 mm
Blade width	6 mm
Blade height	100 mm
Wrench size	0 mm

General

Type	Phillips
Material	alloyed tool steel

Environmental Product Compliance

California Proposition 65	Further information on California's prop. 65 is available under "Downloads" in the manufacturer's declaration
---------------------------	---

Philips screwdriver - SF-PH 2-100 S-VDE - 1212694

Drawings

Pictogram



Philips screwdriver - SF-PH 2-100 S-VDE - 1212694

Dimensional drawing

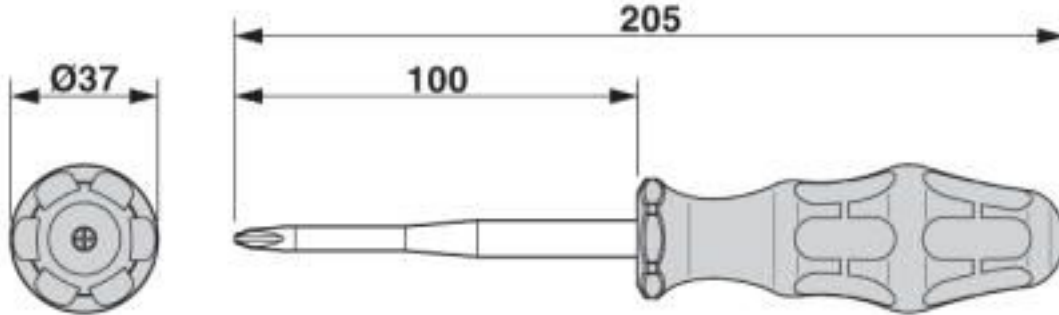

Classifications

eCl@ss

eCl@ss 10.0.1	21040406
eCl@ss 4.0	21040400
eCl@ss 4.1	21040400
eCl@ss 5.0	21040400
eCl@ss 5.1	21040400
eCl@ss 6.0	21040400
eCl@ss 7.0	21040406
eCl@ss 8.0	21040406
eCl@ss 9.0	21040406

ETIM

ETIM 3.0	EC000158
ETIM 4.0	EC000144
ETIM 5.0	EC000144
ETIM 6.0	EC000144
ETIM 7.0	EC000144

UNSPSC

UNSPSC 6.01	27111701
UNSPSC 7.0901	27111701
UNSPSC 11	27111701
UNSPSC 12.01	27111701
UNSPSC 13.2	27111701
UNSPSC 18.0	27111701
UNSPSC 19.0	27111701
UNSPSC 20.0	27111701
UNSPSC 21.0	27111701

Philips screwdriver - SF-PH 2-100 S-VDE - 1212694

Approvals

Approvals

Approvals

VDE Zeichengenehmigung / EAC

Ex Approvals

Approval details

VDE Zeichengenehmigung		http://www2.vde.com/de/Institut/Online-Service/VDE-gepruefteProdukte/Seiten/Online-Suche.aspx	40032921
------------------------	---	---	----------

EAC			RU C- DE.AI30.B.01750
-----	--	--	--------------------------
