

Philips screwdriver - SZK PZ2 VDE - 1206463

Please be informed that the data shown in this PDF Document is generated from our Online Catalog. Please find the complete data in the user's documentation. Our General Terms of Use for Downloads are valid (<http://phoenixcontact.com/download>)



Screwdriver, PZ crosshead, VDE insulated, size: PZ 2 x 100 mm, 2-component grip, with non-slip grip

Your advantages

- VDE approval
- Screwdrivers for Phillips screws with Pozidriv and Phillips Recess screw head

Key Commercial Data

Packing unit	1 pc
GTIN	 4 017918 170929
GTIN	4017918170929
Weight per Piece (excluding packing)	102.020 g
Custom tariff number	82054000
Country of origin	Czech Republic

Technical data

Dimensions

Length (b)	205 mm
Width (a)	37 mm
Blade width	6 mm
Blade height	100 mm
Wrench size	0 mm

General

Type	Phillips
	2
Material	alloyed tool steel
Test standard	DIN/ISO 8764-1 PZ
Weight	80 g

Philips screwdriver - SZK PZ2 VDE - 1206463

Technical data

Standards and Regulations

Test standard	DIN/ISO 8764-1 PZ
---------------	-------------------

Environmental Product Compliance

California Proposition 65	Further information on California's prop. 65 is available under "Downloads" in the manufacturer's declaration
---------------------------	---

Drawings

Dimensional drawing

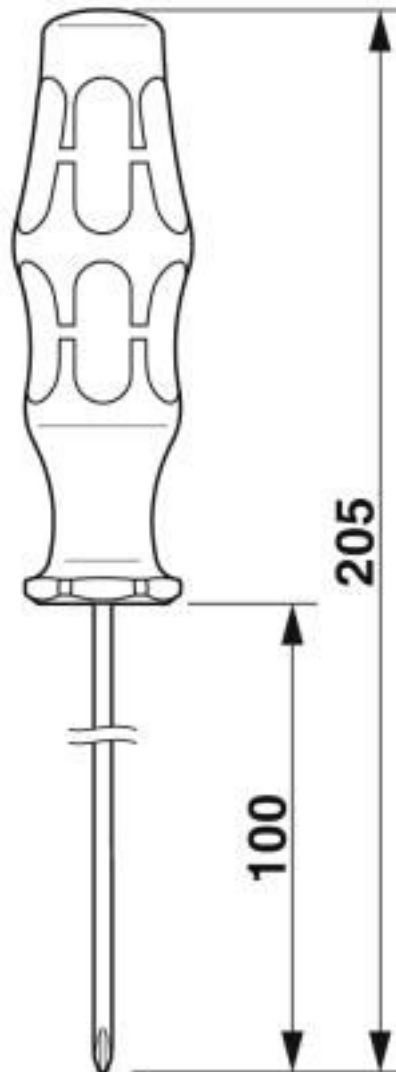

Philips screwdriver - SZK PZ2 VDE - 1206463

Pictogram



Classifications

eCl@ss

eCl@ss 10.0.1	21040406
eCl@ss 4.0	21040400
eCl@ss 4.1	21040400
eCl@ss 5.0	21040400
eCl@ss 5.1	21040400
eCl@ss 6.0	21040400
eCl@ss 7.0	21040406

Philips screwdriver - SZK PZ2 VDE - 1206463

Classifications

eCl@ss

eCl@ss 8.0	21040406
eCl@ss 9.0	21040406

ETIM

ETIM 2.0	EC000144
ETIM 3.0	EC000144
ETIM 4.0	EC000144
ETIM 5.0	EC000144
ETIM 6.0	EC000144
ETIM 7.0	EC000144

UNSPSC

UNSPSC 6.01	27111701
UNSPSC 7.0901	27111701
UNSPSC 11	27111701
UNSPSC 12.01	27111701
UNSPSC 13.2	27111701
UNSPSC 18.0	27111701
UNSPSC 19.0	27111701
UNSPSC 20.0	27111701
UNSPSC 21.0	27111701

Approvals

Approvals

Approvals

VDE Zeichengenehmigung / EAC

Ex Approvals

Approval details

VDE Zeichengenehmigung		http://www2.vde.com/de/Institut/Online-Service/VDE-gepruefteProdukte/Seiten/Online-Suche.aspx	086858
------------------------	---	---	--------

Philips screwdriver - SZK PZ2 VDE - 1206463

Approvals

EAC



RU x-
DE.xx08.B.02974